

TurnLine

BXA20

www.tungaloy.com

Tungaloy Report No. 511-G

BXA20

Coated CBN grade with a whole new level of cutting performance for hardened steel



Member IMC Group
Tungaloy

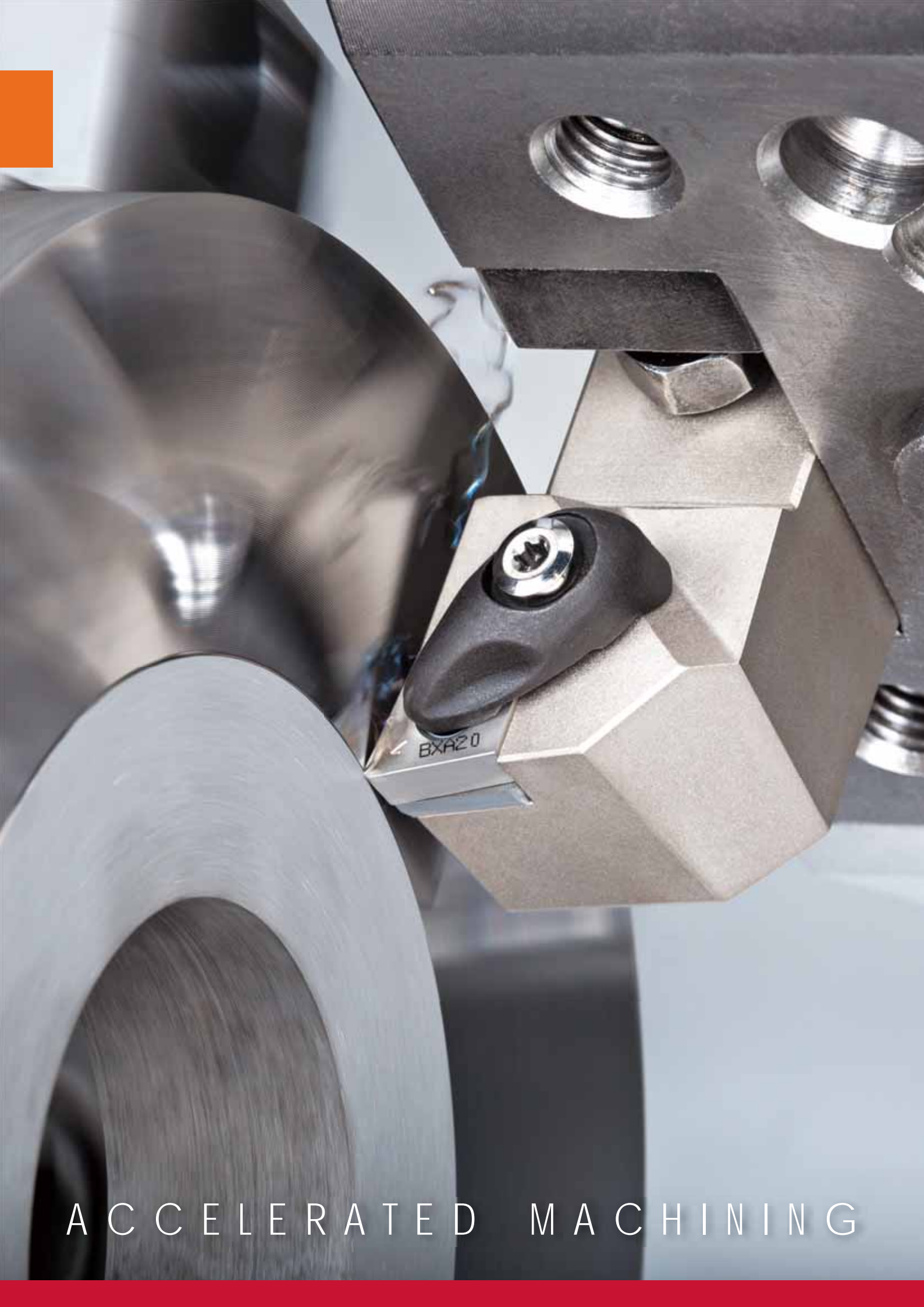

ACCELERATED MACHINING



TurnLine

BXA20

TUNGALOY



Remarkably long tool life in hardened steel turning
with a **new coating layer and CBN substrate**

www.tungaloy.com

Incredible reliability in hardened steel turning

- Suitable for operations at low to medium cutting speed
- Covers a wide range of application areas from continuous to heavy interrupted cutting

Multi-layered coating 2 times thicker than the conventional grade

- Provides excellent wear resistance

Improved adhesion strength

- Prevents peeling-off, providing excellent surface finish

Newly developed CBN substrate

- Optimum CBN content for high wear resistance and toughness

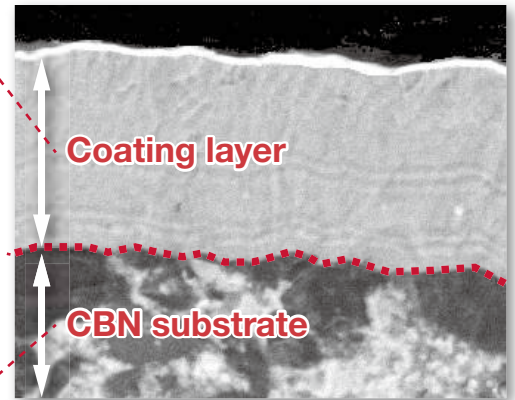

APPLICATION AREA

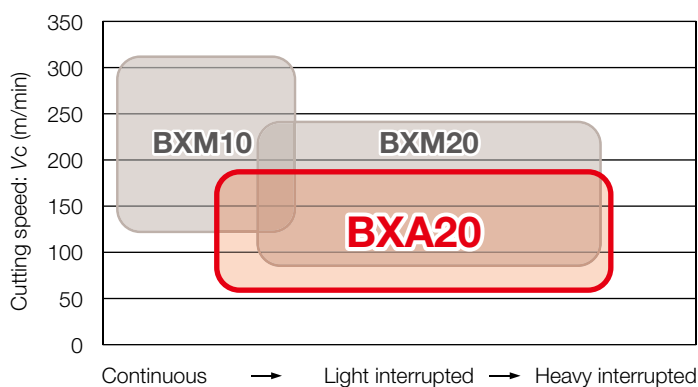

BXM10

Suitable for continuous to light interrupted cutting at high speed

BXM20

Suitable for continuous to heavy cutting at medium and high speed

BXA20

Great performance for continuous to heavy cutting at low and medium speed

CUTTING PERFORMANCE

Machining length 0.7 km

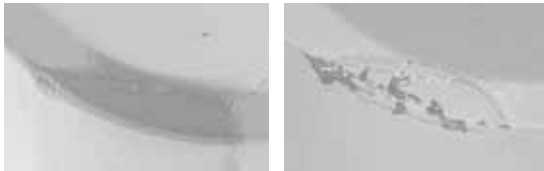

BXA20

Conventional grade

Machining length 1.4 km



BXA20

Conventional grade

H Insert : 2QP-CNGA120408
 Workpiece material : SCM420 (60HRC)
 Cutting speed : $V_c = 100$ m/min
 Feed : $f = 0.1$ mm/rev
 Depth of cut : $a_p = 0.2$ mm
 Machining : Face turning
 (interrupted cutting)

Without peeling-off, tool life is extended even in heavy interrupted machining.

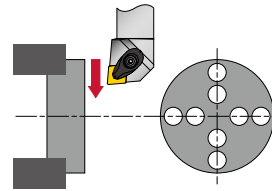



















STANDARD CUTTING CONDITIONS

ISO	Grade	Workpiece condition	Cutting speed V_c (m/min)	Depth of cut a_p (mm)	Feed f (mm/rev)
H	BXA20	Continuous	130 (60 - 180)	0.3 (0.05 - 0.50)	0.1 (0.05 - 0.30)
	BXA20	Interrupted	130 (60 - 180)	0.2 (0.05 - 0.30)	0.1 (0.05 - 0.20)

GRADE

Application	Grade Application code	Microstructure	Hardness (Hv)	T.R.S (Gpa)
H	BXA20 H10-H20		3500 - 3700	1.35 - 1.50

INSERTS





Feature	Shape	Designation	Grade	No. of corners	I. C. dia. <i>ød</i>	Thick-ness <i>s</i>	Hole dia. <i>ød1</i>	Corner radius <i>r_c</i>	CBN length <i>a</i>	
			Coated							
			BXA20							
Standard		2QP-CNGA120404	●	2	12.7	4.76	5.16	0.4	2.3	
		2QP-CNGA120408	●	2	12.7	4.76	5.16	0.8	2.2	
		2QP-CNGA120412	●	2	12.7	4.76	5.16	1.2	2.4	
		2QP-DNGA150408	●	2	12.7	4.76	5.16	0.8	2.1	
		2QP-DNGA150608	●	2	12.7	6.35	5.16	0.8	2.1	
		3QP-TNGA160404	●	3	9.525	4.76	3.81	0.4	2.2	
		3QP-TNGA160408	●	3	9.525	4.76	3.81	0.8	1.9	
		3QP-TNGA160412	●	3	9.525	4.76	3.81	1.2	2.4	
		2QP-VNGA160404	●	2	9.525	4.76	3.81	0.4	3.1	
		2QP-VNGA160408	●	2	9.525	4.76	3.81	0.8	2.2	
		3QP-WNGA080408	●	3	12.7	4.76	3.81	0.8	2.2	
		2QP-GNGA120404	●	2	-	4.76	5.16	0.4	2.3	
		2QP-GNGA120408	●	2	-	4.76	5.16	0.8	2.2	
		2QP-GNGA120412	●	2	-	4.76	5.16	1.2	2.4	
	Heavy honing		2QP-CNGA120408-H	●	2	12.7	4.76	5.16	0.8	2.2
			2QP-DNGA150408-H	●	2	12.7	4.76	5.16	0.8	2.1
			3QP-TNGA160408-H	●	3	9.525	4.76	3.81	0.8	1.9
			3QP-TNGA160412-H	●	3	9.525	4.76	3.81	1.2	2.4
		2QP-VNGA160404-H	●	2	9.525	4.76	3.81	0.4	3.1	
With chipbreaker		2QP-CNGM120408-HM	●	2	12.7	4.76	5.16	0.8	2.2	
		2QP-CNGM120412-HM	●	2	12.7	4.76	5.16	1.2	2.4	
With wiper		2QP-CNGA120408WL	●	2	12.7	4.76	5.16	0.8	2.2	
		2QP-DNGA150404WJ	●	2	12.7	4.76	5.16	0.4	2.1	
		2QP-DNGA150408WJ	●	2	12.7	4.76	5.16	0.8	2.1	
Standard		3QP-TNGA160404WG	●	3	9.525	4.76	3.81	0.4	2.2	
		2QP-CCGW060204	●	2	6.35	2.38	2.8	0.4	2.3	
		2QP-CCGW09T304	●	2	9.525	3.97	4.4	0.4	2.3	
		2QP-CCGW09T308	●	2	9.525	3.97	4.4	0.8	2.2	
		2QP-DCGW070202	●	2	6.35	2.38	2.8	0.2	2.7	
		2QP-DCGW070204	●	2	6.35	2.38	2.8	0.4	2.5	
		2QP-DCGW11T308	●	2	9.525	3.97	4.4	0.8	2.1	
		3QP-TPGW110304	●	3	6.35	3.18	3.4	0.4	2.2	
		3QP-TPGW110308	●	3	6.35	3.18	3.4	0.8	2.0	
		2QP-VBGW110304	●	2	6.35	3.18	2.8	0.4	3.1	
2QP-VBGW110308		●	2	6.35	3.18	2.8	0.8	2.2		
2QP-VBGW160404		●	2	9.525	4.76	4.4	0.4	3.1		
	2QP-VBGW160408	●	2	9.525	4.76	4.4	0.8	2.2		

● : Line-up

Specification of standard honing

	BXA20
Negative inserts	S01325
Positive inserts	S01325

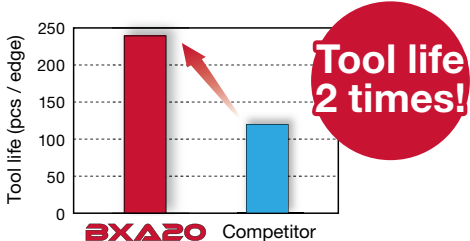
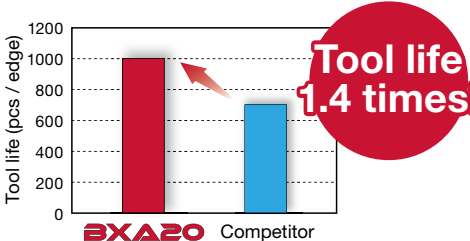
PRACTICAL EXAMPLES

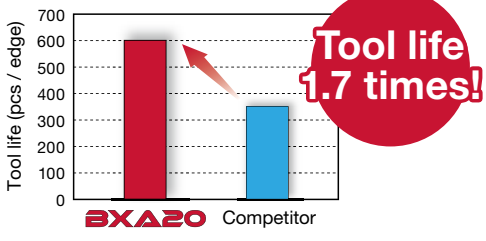
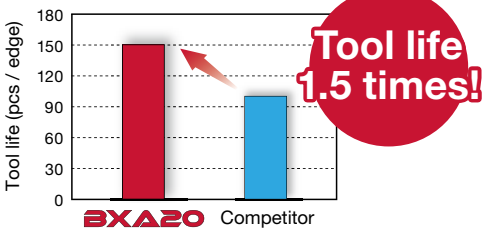
Workpiece type		Automotive parts (CVT)	Automotive parts (CVJ)
Insert		2QP-DNGA150412	2QP-DNGA150420
Grade		BXA20	BXA20
Workpiece material		SCr420H (59HRC)	SCr420H (60HRC)
		 H	 H
Cutting conditions	Cutting speed: V_c (m/min)	170	150
	Feed : f (mm/rev)	0.3	0.25
	Depth of cut : a_p (mm)	0.1	0.2
	Coolant	Wet	Wet
Results		 <p>Tool life 2 times!</p> <p>Tool life is doubled due to higher wear resistance.</p>	 <p>Tool life 1.4 times!</p> <p>The operation is stable with BXA20 even in interrupted machining.</p>
Workpiece type		Automotive parts (Poppet)	Machine parts
Insert		2QP-CCGW09T304	2QP-DNGA150404
Grade		BXA20	BXA20
Workpiece material		SCr415H (58HRC)	SNCM420H (60HRC)
		 H	 H
Cutting conditions	Cutting speed: V_c (m/min)	130	150
	Feed : f (mm/rev)	0.04	0.07
	Depth of cut : a_p (mm)	0.2	0.15
	Coolant	Wet	Wet
Results		 <p>Tool life 1.7 times!</p> <p>BXA20 provides stable tool life as only normal wear occurs without chipping.</p>	 <p>Tool life 1.5 times!</p> <p>Surface roughness is minimized with BXA20.</p>

Tungaloy Corporation (Head office)

11-1 Yoshima-Kogyodanchi
Iwaki-city, Fukushima, 970-1144 Japan
Phone: +81-246-36-8501
Fax: +81-246-36-8542
www.tungaloy.co.jp

Tungaloy America, Inc.

3726 N Ventura Drive
Arlington Heights, IL 60004, U.S.A.
Phone: +1-888-554-8394
Fax: +1-888-554-8392
www.tungaloyamerica.com

Tungaloy Canada

432 Elgin St. Unit 3
Brantford, Ontario N3S 7P7, Canada
Phone: +1-519-758-5779
Fax: +1-519-758-5791
www.tungaloy.co.jp/ca

Tungaloy de Mexico S.A.

C Los Arellano 113,
Parque Industrial Siglo XXI
Aguascalientes, AGS, Mexico 20290
Phone: +52-449-929-5410
Fax: +52-449-929-5411
www.tungaloy.co.jp/mx

Tungaloy do Brasil Ltda.

Avd. Independencia N4158 Residencial Flora
13280-000 Vinhedo, São Paulo, Brasil
Phone: +55-19-38262757
Fax: +55-19-38262757
www.tungaloy.com/br

Tungaloy Germany GmbH

An der Alten Ziegelei 1
D-40789 Monheim, Germany
Phone: +49-2173-90420-0
Fax: +49-2173-90420-19
www.tungaloy.de

Tungaloy France S.A.S.

ZA Courtaboeuf - Le Rio
1 rue de la Terre de feu
F-91952 Courtaboeuf Cedex, France
Phone: +33-1-6486-4300
Fax: +33-1-6907-7817
www.tungaloy.fr

Tungaloy Italia S.r.l.

Via E. Andolfato 10
I-20126 Milano, Italy
Phone: +39-02-252012-1
Fax: +39-02-252012-65
www.tungaloy.it

Tungaloy Czech s.r.o.

Turanka 115
CZ-627 00 Brno, Czech Republic
Phone: +420-532 123 391
Fax: +420-532 123 392
www.tungaloy.cz

Tungaloy Ibérica S.L.

C/Miquel Servet, 43B, Nau 7
Pol. Ind. Bufalvent
ES-08243 Manresa (BCN), Spain
Phone: +34 93 113 1360
Fax: +34 93 876 2798
www.tungaloy.es

Tungaloy Scandinavia AB

Bultgatan 38
442 40 Kungälv, Sweden
Phone: +46-462119200
Fax: +46-462119207
www.tungaloy.se

Tungaloy Rus, LLC

36-D Harkovsky Lane
308009 Belgorod, Russia
Phone: +7 4722 24 00 07
Fax: +7 4722 24 00 08
www.tungaloy.com/ru

Tungaloy East LLC

Stachek str., h.4, office 2, Ekaterinburg,
620017, Russia
Phone: +7-343-389-13-22
Fax: +7-343-278-94-35
www.tungaloy.com/jp/rue

Tungaloy Polska Sp. z o.o.

ul. Genewska 24
03-963 Warszawa, Poland
Phone: +48-22-617-0890
Fax: +48-22-617-0890
www.tungaloy.com/jp/pl

Tungaloy U.K. Ltd

The Technology Centre,
Wolverhampton Science Park
Glaisher Drive, Wolverhampton
West Midlands WV10 9RU, UK
Phone: +44 121 4000 231
Fax: +44 121 270 9694
www.tungaloy.com/jp/uk
salesinfo@tungaloyuk.co.uk

Tungaloy Hungary Kft

Erzsébet királyné útja 125
H-1142 Budapest, Hungary
Phone: +36 1 781-6846
Fax: +36 1 781-6866
www.tungaloy.com/jp/hu
info@tungaloytools.hu

Tungaloy Turkey

Dudullu, OSB 4. Cad No:4
34776 Umraniye Istanbul, TURKEY
Phone: +90 216 540 04 67
Fax: +90 216 540 04 87
www.tungaloy.com.tr
info@tungaloy.com.tr

Tungaloy Benelux b.v.

Tjalk 70
NL-2411 NZ Bodegraven, Netherlands
Phone: +31 172 630 420
Fax: +31 172 630 429
www.tungaloy-benelux.com

Tungaloy Croatia

Josipa Kozarca 4
10432 Bregana, Croatia
Phone: +385 1 3326 604
Fax: +385 1 3327 683
www.tungaloy.hr

Tungaloy Cutting Tool (Shanghai) Co., Ltd.

Rm No 401 No.88 Zhabei
Jiangchang No.3 Rd
Shanghai 200436, China
Phone: +86-21-3632-1880
Fax: +86-21-3621-1918
www.tungaloy.com/jp/tcts

Tungaloy Cutting Tool (Thailand) Co., Ltd.

Interlink tower 4th Fl.
1858/5-7 Bangna-Trad Road
km.5 Bangna, Bangna, Bangkok 10260
Thailand
Phone: +66-2-751-5711
Fax: +66-2-751-5715
www.tungaloy.co.th

Tungaloy Singapore (Pte.), Ltd.

62 Ubi Road 1, #06-11 Oxley BizHub 2
Singapore 408734
Phone: +65-6391-1833
Fax: +65-6299-4557
www.tungaloy.com/jp/tspl

Tungaloy Vietnam

Unit 18, 4th Fl. Saigon Centre Building
65 Le Loi Blvd.
Dist 1, Ho Chi Minh City, Vietnam
Phone: +84-8-3827-0201
Fax: +84-8-3827-0203
www.tungaloy.com/jp/tspl

Tungaloy India Pvt. Ltd.

Indiabulls Finance Centre,
Unit # 902-A, 9th Floor,
Tower 1, Senapati Bapat Marg,
Elphinstone Road (West),
Mumbai-400013, India
Phone: +91-22-6124-8804
Fax: +91-22-6124-8899
www.tungaloy.com/jp/in

Tungaloy Korea Co., Ltd

#1312, Byucksan Digital Valley 5-cha
Beotkkot-ro 244, Geumcheon-gu
153-788 Seoul, Korea
Phone: +82-2-2621-6161
Fax: +82-2-6393-8952
www.tungaloy.com/jp/kr

Tungaloy Malaysia Sdn Bhd

50 K-2, Kelana Mall, Jalan SS6/14
Kelana Jaya, 47301
Petaling Jaya, Selangor Darul Ehsan
Malaysia
Phone: +603-7805-3222
Fax: +603-7804-8563
www.tungaloy.com/jp/my

Tungaloy Australia Pty Ltd

PO Box 2232, Rowville,
Victoria 3178, Australia
Phone: +61-3-9755-8147
Fax: +61-3-9755-6070
www.tungaloy.com.au

PT. Tungaloy Indonesia

Kompleks Grand Wisata Block AA-10 No.3-5
Cibitung
Bekasi 17510, Indonesia
Phone: +62-21-8261-5808
Fax: +62-21-8261-5809
www.tungaloy.com/jp/id



www.tungaloy.com

follow us at:

facebook.com/tungaloyjapan

twitter.com/tungaloyjapan

To see this product in action visit:

Tung-TV

www.youtube.com/tungaloycorporation

Distributed by:



DOWNLOAD
Dr. Carbide
Tungaloy



Available on the
App Store



GET IT ON
Google play



ISO 9001 Certified
QC00J0056
Tungaloy Corporation
18/10/1996

ISO 14001 Certified
EC97J1123
Tungaloy Corporation
26/11/1997