

GrooveLine

TUNGCUT

www.tungaloy.com

Tungaloy Report No. 391-G



Now available with **high-pressure coolant holders**
and new chipbreakers for high-productivity grooving



INDUSTRY 4.0
FEED the SPEED!

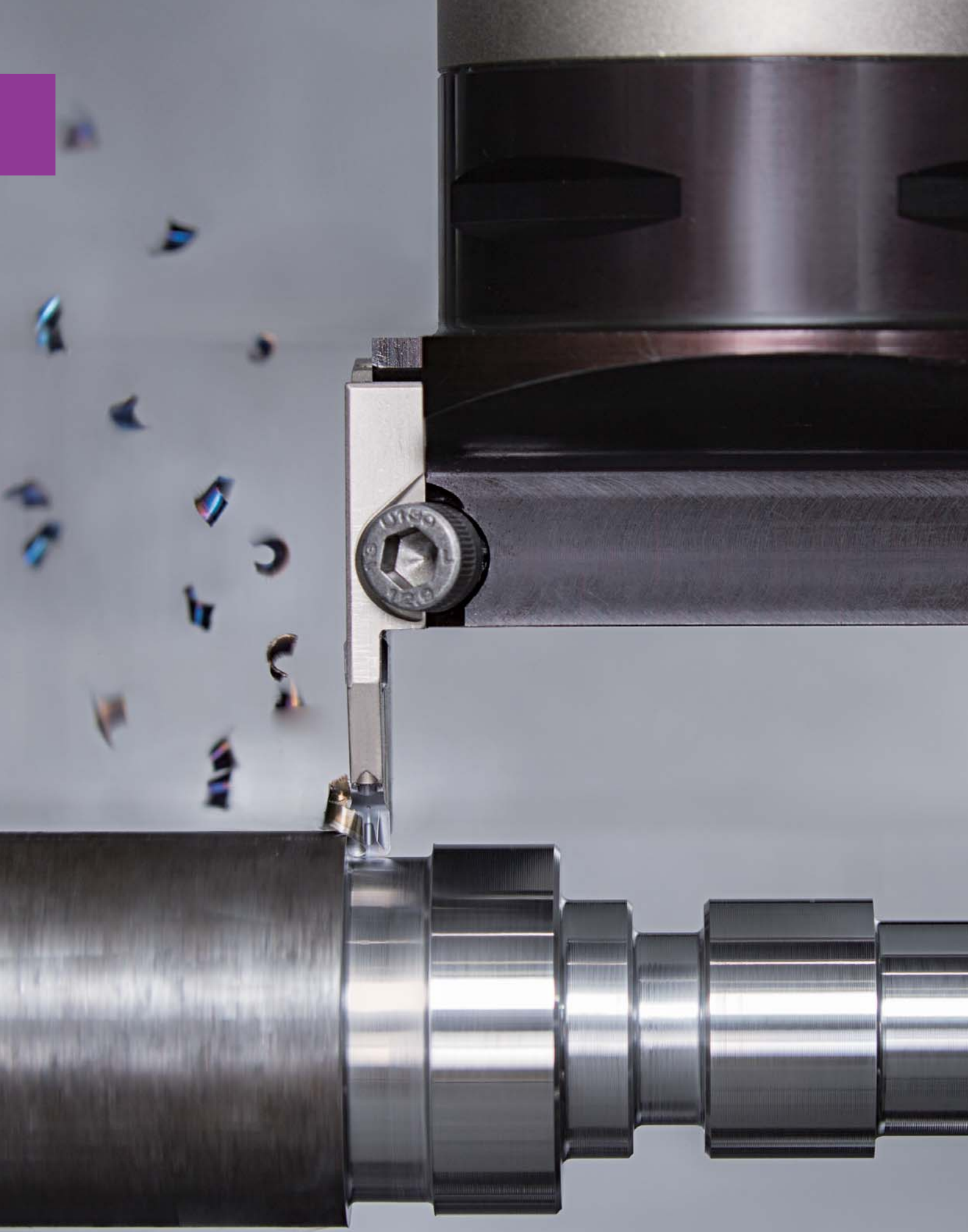

ACCELERATED MACHINING

TUNG FORCE
TURN
ACCELERATED MACHINING



Multi-functional tool reduces tool cost and shortens set-up time.

Various insert grades are applicable for a wide range of applications.

High-pressure coolant system improves chip flow and tool life

New modular holder system adds versatility to existing monoblock holder and TungCap (PSC) lines.

New



Multi-functional grooving system

Suitable for diverse grooving operations

External grooving, turning, and parting

New **CTER/L-CHP (P.25)**

CTER/L (P.26)

- Screw clamp
- W (for external coolant) = 2 mm - 8 mm
- W (for high pressure coolant) = 2 mm - 8 mm
- ar = 8 mm - 36 mm
- Shank size: 16mm - 32 mm

JCTER/L (P.36)

- Screw clamp
- W = 1.4 mm - 3 mm
- ar = 10 mm - 16 mm
- Shank size: 10mm - 20 mm
- For small auto lathe

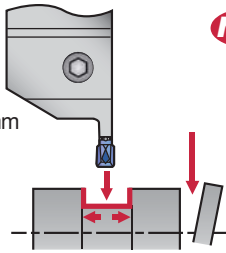

New **CAER/L-CHP (P.40)**

CAER/L (P.44)

- Blade type
- Screw clamp
- W (for external coolant) = 3 mm - 6 mm
- W (for high pressure coolant) = 3 mm - 6 mm
- ar = 16 mm - 20 mm
- Shank size: 20mm - 32 mm

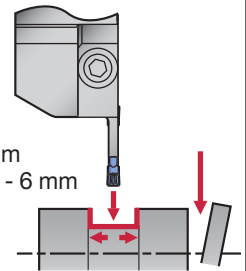

CGER/L (P.37)

- Self clamp
- W = 1.4 mm - 3 mm
- ar = 10 mm - 16 mm
- Shank size: 10 mm - 20 mm
- For small auto lathe

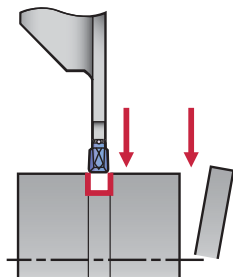

CGP (P.38)

- Self clamp
- W = 1.4 mm - 8 mm
- Max parting dia: ø120 mm
- Shank size: 20 mm - 25 mm

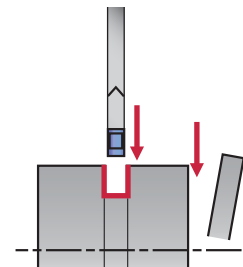

External and internal undercutting

CGEUR/L (P.29)

- Screw clamp
- W = 3 mm - 6 mm
- ar = 2.8 mm - 3.4 mm
- Shank size: 16 mm - 25 mm

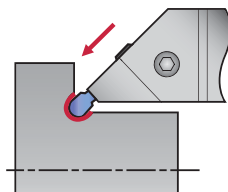

CGIUR/L (P.32)

- Screw clamp
- W = 3 mm - 6 mm
- ar = 2.8 mm
- Shank size: ø20 mm - ø25 mm

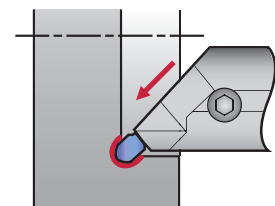

External and face grooving, and turning

CTEFR/L (P.28)

- Screw clamp
- $W = 2 \text{ mm} - 6 \text{ mm}$
- $ar = 4.8 \text{ mm}$
- Shank size:
20 mm - 25 mm
- Minimum face grooving diameter:
 $\phi D_{min} \phi 19 -$

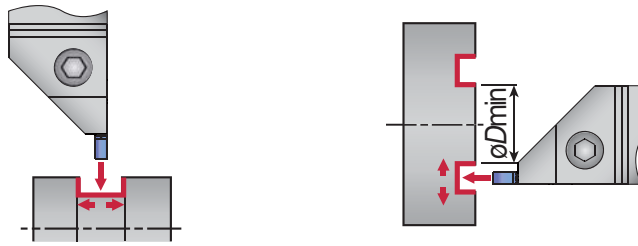

Face grooving and turning

CTFR/L (P.33)

- Screw clamp
- $W = 3 \text{ mm} - 6 \text{ mm}$
- $ar = 10 \text{ mm} - 25 \text{ mm}$
- Shank size: 25 mm
- Minimum face grooving diameter:
 $\phi D_{min} \phi 24 -$

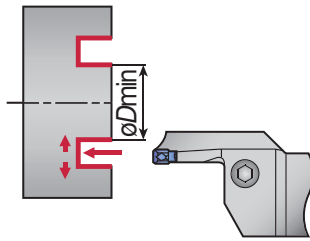

CAFR/L (P.45)

- Blade type
- Screw clamp
- $W = 3 \text{ mm} - 6 \text{ mm}$
- $ar = 12 \text{ mm} - 25 \text{ mm}$
- Shank size:
20 mm - 32 mm
- Minimum face grooving diameter:
 $\phi D_{min} \phi 40 -$

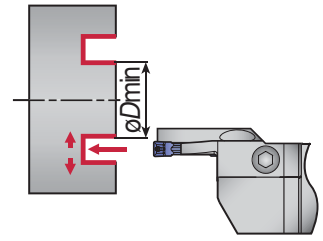

CTFVR/L (P.34)

- Screw clamp
- $W = 3 \text{ mm} - 6 \text{ mm}$
- $ar = 10 \text{ mm} - 20 \text{ mm}$
- Shank size: 25 mm
- Minimum face grooving diameter:
 $\phi D_{min} \phi 24 -$

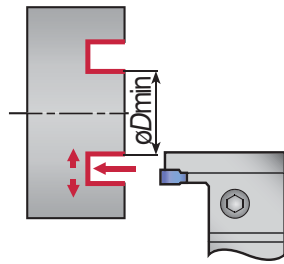

Face grooving, internal face grooving and turning

CTIFR/L (P.31)

- Screw clamp
- $W = 3 \text{ mm} - 6 \text{ mm}$
- $ar = 5.5 \text{ mm}$
- Shank size:
 $\phi 25 \text{ mm} - \phi 32 \text{ mm}$
- Minimum face grooving diameter: $\phi D_{min} \phi 19 -$
- Minimum bore diameter: $\phi D_m \phi 26.3 -$

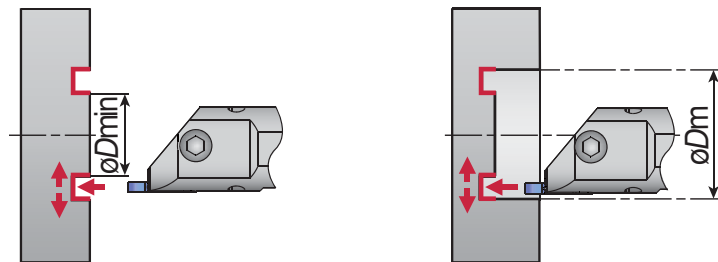

Internal grooving and turning

CTIR/L (P.30)

- Screw clamp
- $W = 2 \text{ mm} - 8 \text{ mm}$
- $ar = 4 \text{ mm} - 10 \text{ mm}$
- Shank size: $\phi 16 \text{ mm} - \phi 40 \text{ mm}$
- Minimum bore diameter:
 $\phi D_m \phi 25 -$

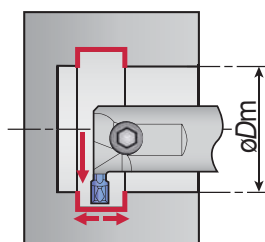

New

TungTurnJet's effects

Drastically improved tool life with high pressure coolant

P Steel : External grooving
(S45C / C45 , 245HB)

Material : S45C
Toolholder : CHSL2525-CHP + CAEL-3T20-CHP
Insert : DGM3-020 AH7025
Cutting speed : $V_c = 180$ m/min
Feed : $f = 0.12$ mm/rev
Groove width : $W = 3$ mm

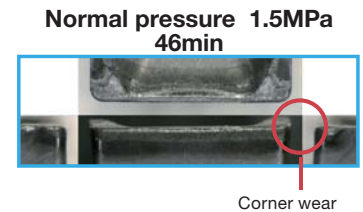
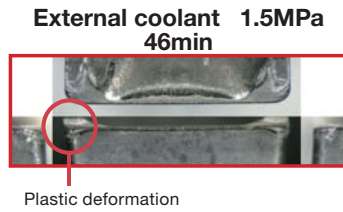
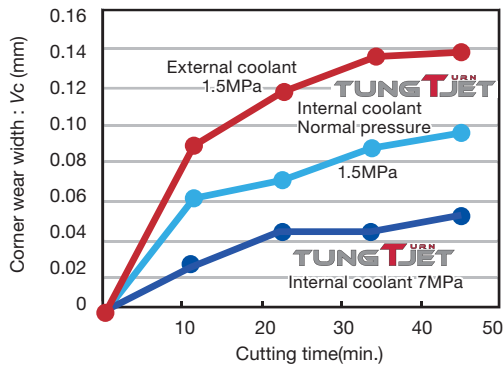

Excellent chip control with high pressure coolant

P Steel : External Grooving
(S45C / C45 , 245HB)

Material : S45C
Holder : CHSL2525-CHP + CAEL-3T20-CHP
Insert : DGS3-020 AH7025
DTX3-030 AH7025
Cutting speed : $V_c = 180$ m/min
Feed rate : $f = 0.05$ mm/rev
Groove width : $W = 3$ mm

DGS

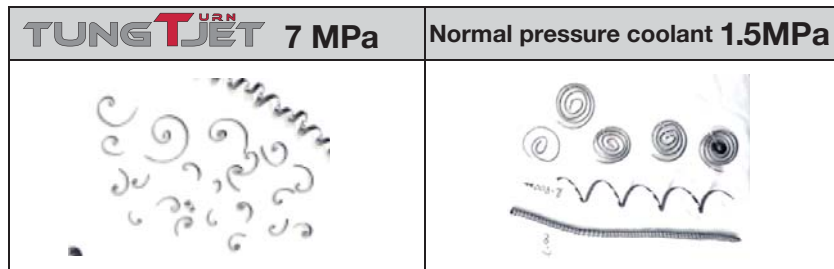
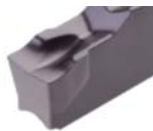

DTX

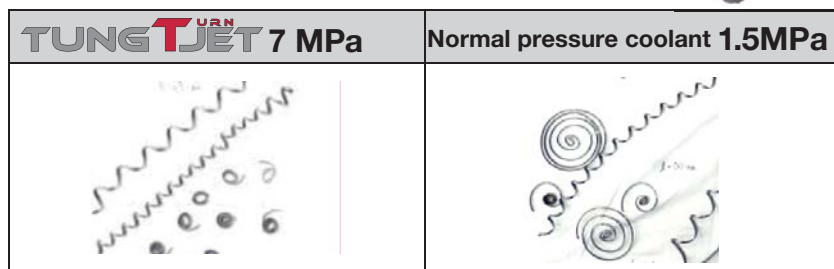



Excellent chip control with high pressure coolant

S Inconel 718

DGS





Material : Inconel718
 Holder : C6CHSL45050 + CAEL-3T20-CHP
 Insert : DGS3-020 AH7025
 DGG300-020 KS05F
 Cutting speed : $V_c = 40$ m/min
 Feed rate : $f = 0.05$ mm/rev
 Groove width : $W = 3$ mm

| TUNG T ^{URN} JET 7 MPa | Normal pressure coolant 1.5MPa |
|---|---|
|  |  |

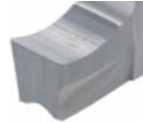
DGG



| TUNG T ^{URN} JET 7 MPa | Normal pressure coolant 1.5MPa |
|---|---|
|  |  |



GROOVING, PARTING, AND TURNING

DTE

Good chip evacuation in turning at high feed due to the wide distance between the cutting edge and the chip former.



New DTM

First choice chipbreaker for general purpose. Optimized chipbreaker width facilitates smooth chipbreaking and flow.



DTX

- Good cutting performance in grooving.
- Excellent chip formation in turning at low feed as the distance between the cutting edge and the chip former is small.



P

Carbon steel
(S45C / C45)

M

Stainless steel
(SUS304 / X5CrNi18-9)

DTE4-040

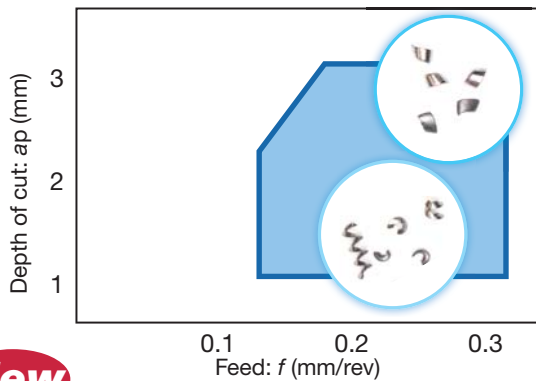

DTE4-040

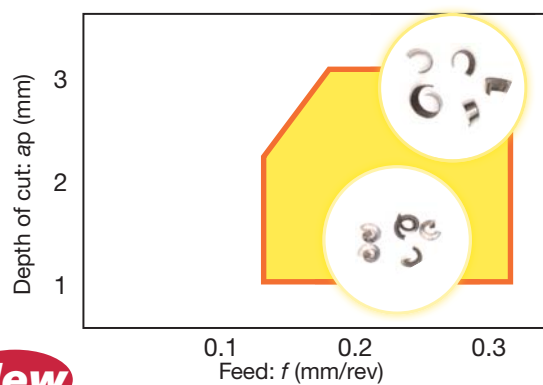

New

DTM4-040

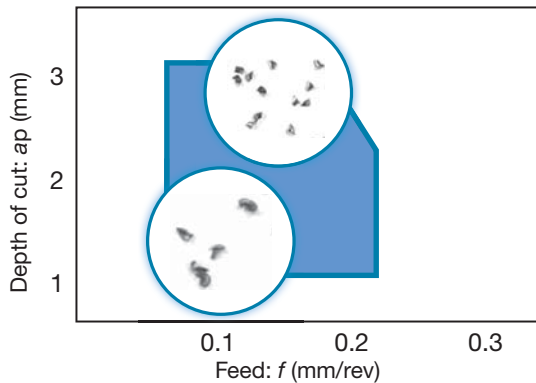

New

DTM4-040

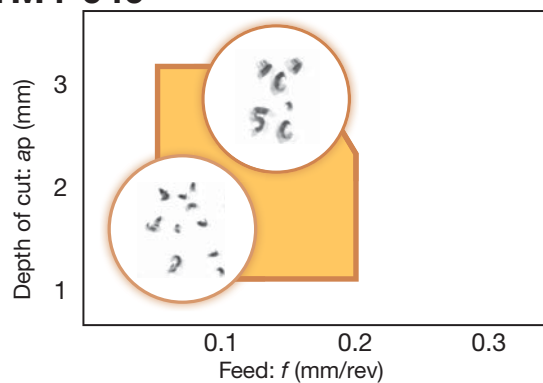

DTX4-040

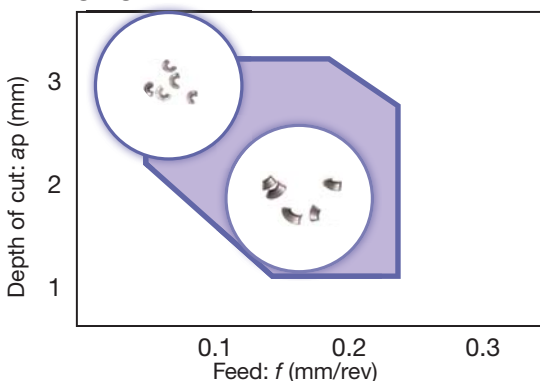

DTX4-040

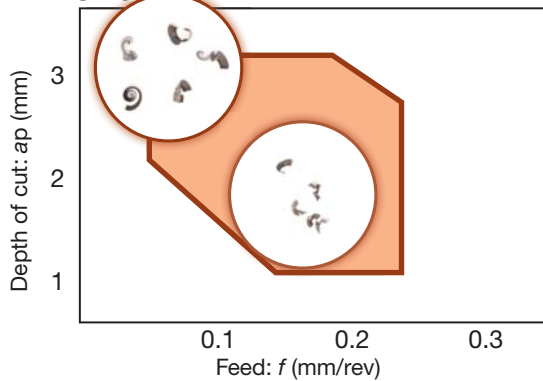

Unique chipbreaker provides excellent chip formation under various conditions.



GROOVING AND PARTING

Carbon steel
(S45C / C45)



DGM4-030

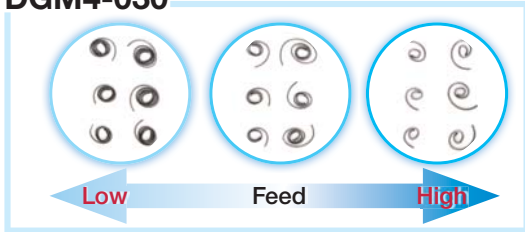

DGS4-030

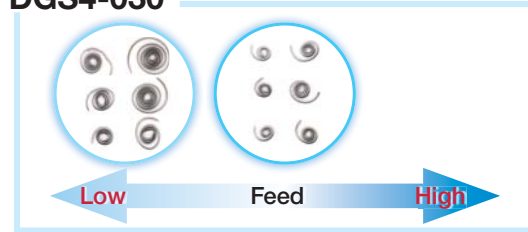

DTE4-040

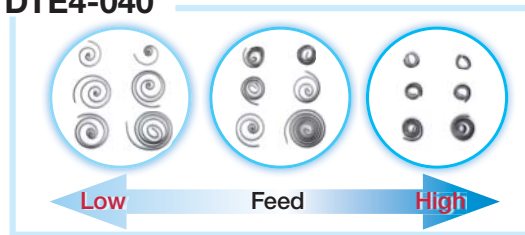

DTX4-040

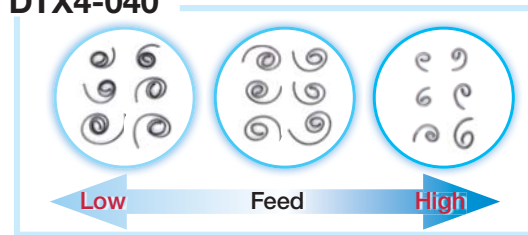

DTE400-040

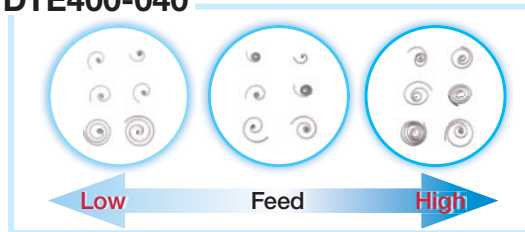

New DTM4-040

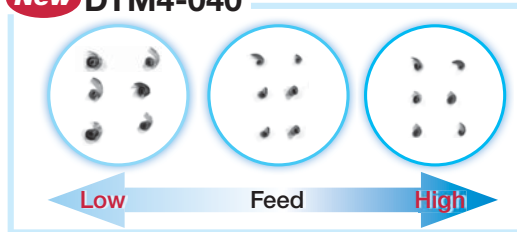

GROOVING AND PARTING

Stainless steel
(SUS304 / X5CrNi18-9)



DGM4-030

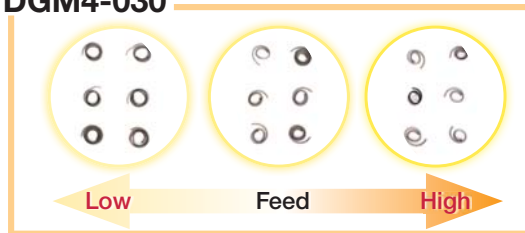

DGS4-030

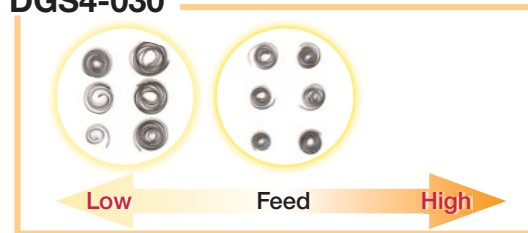

DTE4-040

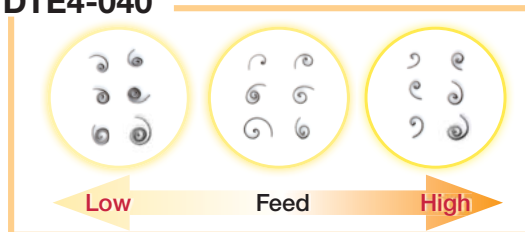

DTX

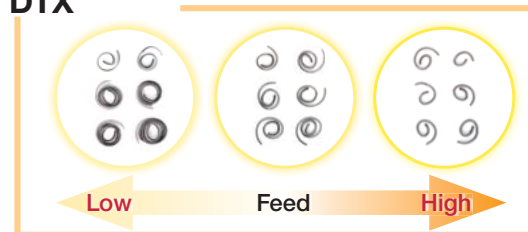

DTE400-040

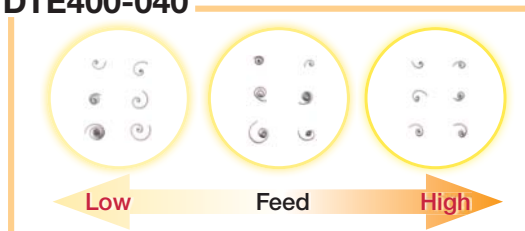

New DTM4-040

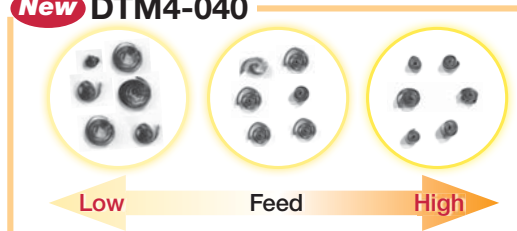

CUTTING PERFORMANCE

First choice grade for grooving application

New AH7025 grade - Drastically improved reliability with world's first technology

Tool life comparison in grooving

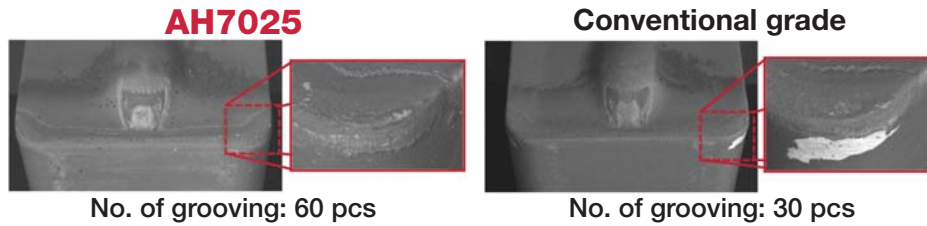

No. of grooving: 60 pcs

No. of grooving: 30 pcs

New AH7025 grade allows stable machining without peeling off, even in twice longer cutting time than conventional grade.

→ **The combination of Nano-multi-layered AlTiN Coating with high Al content and tough substrate provides highly efficient machining in various grooving operations.**

Alloy steel **P**
(SCM440 / 42CrMo4)

Insert : DTE3-040 AH7025
Cutting speed : $V_c = 150$ m/min
Feed : $f = 0.17$ mm/rev
Groove depth : 17 mm
Machining : External grooving
Coolant : Wet

GRADES

New

AH7025

P M
S

- First recommended grade for general purpose
- New PVD coating with high Al content provides excellent adhesion strength
- Improved wear and chipping resistance

AH725

P M
S

- Recommended for general purpose machining
- Newly developed coating with well controlled crystal structure and fracture resistance
- Improved adhesion strength

T9125

P

- Suitable for steel machining at high speed
- New CVD coating and substrate deliver an outstanding balance of wear and chipping resistance

NS9530

P

- Advanced cermet for finish cutting of steel
- Innovative grade with incredible fracture and high wear resistance

GH130

P M
K

- Recommended for interrupted machining
- TiCNO PVD coating layer with high wear resistance
- High hardness and wear resistance

AH905

S

- Remarkable for machining of heat resistant alloy
- Exclusive coating layer improves adhesion strength and wear resistance

TH10

N

- Recommended for non-ferrous materials

BX360

H

- Suitable for hardened steel machining
- Ideal balance of wear and chipping resistance due to the optimum CBN content and grain size

KS05F

N S

- Recommended for non-ferrous materials and titanium

High clamping rigidity

For stable tool life and accuracy

Clamping system

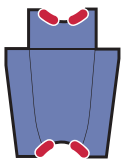

• Stable and safe contact points!

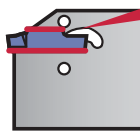

High repeatability and durability due to long pocket!

Limited cutting edge displacement

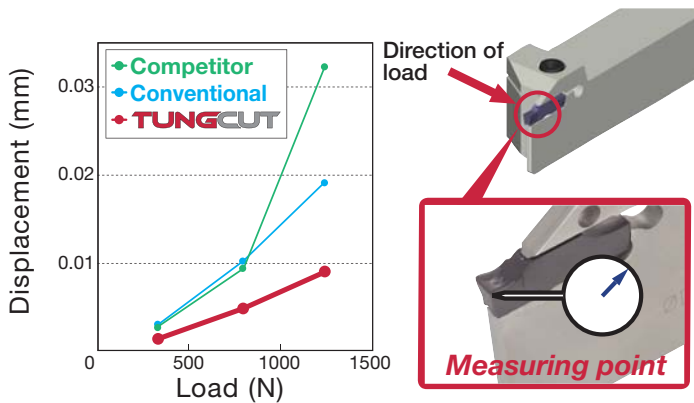

NOTICE IN "TURNING"

When turning, the insert is pushed by the directional cutting force feed. As a result of this condition the diameter of the workpiece may change. (see Fig. 1) In such cases, trial cutting is

essential to measure the actual diameter. For your reference, sample of compensated values are shown in Fig. 2.

Fig. 1

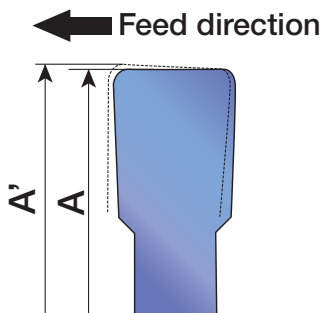
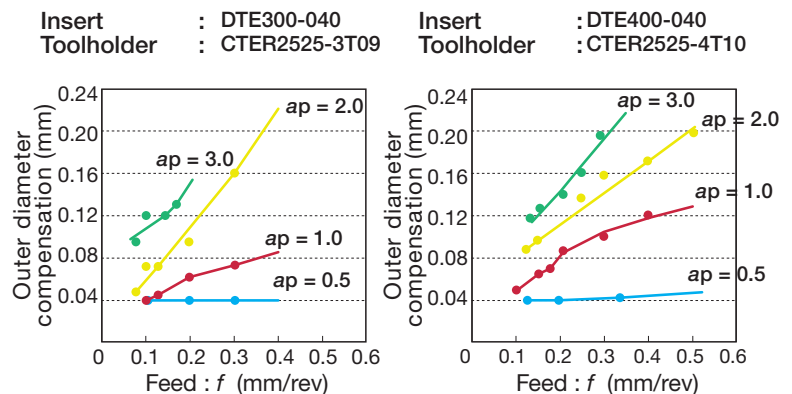

Fig. 2 Value of compensation



GRADES

| Grade | Substrate | | Coating layer | | Features |
|-------------------|------------------|----------------|---------------------------------------|----------------|--|
| | Specific gravity | Hardness | Main Composition | Thickness (µm) | |
| New AH7025 | 14.4 | 91.3 HRA | (Al,Ti)N | 3.5 | First recommended grade with excellent wear resistance and toughness, that is suitable for machining of a wide range of materials. |
| AH725 | 14.4 | 91.5 HRA | (Ti,Al)N | 2 | PVD coated "Flash-coating" fine grain cemented carbide |
| T9125 | 13.7 | 90.0 HRA | TiCN + Al ₂ O ₃ | 16 | This versatile grade dramatically improves chipping resistance |
| NS9530 | 6.8 | 91.7 HRA | - | - | Versatile cermet grade with incredible fracture and wear resistance |
| GH130 | 14.1 | 89.5 HRA | TiCNO | 3 | Superior resistance to chipping and fracture Excels in interrupted cutting |
| AH905 | 15.0 | 93.0 HRA | (Al,Ti)N | 1.5 | Excels in both cutting edge sharpness and wear resistance |
| TH10 | 14.7 | 92.0 HRA | - | - | Carbide grade with excellent wear resistance and toughness |
| KS05F | 15.0 | 93.0 HRA | - | - | Carbide grade with excellent wear, fracture, and chip-welding resistances |
| BX360 | - | 3200 - 3400 Hv | - | - | CBN grade with exceptional balance of wear and chipping resistance |

INSERT APPLICATION

| Insert | Application | | | | | | |
|----------------|-------------------|-------------------|------|---------|-------------------------|-------------------------|------|
| | Grooving | | | Parting | Turning | | |
| | External | Internal | Face | | External | Internal | Face |
| DGM / SGM | ● | | ● | ● | | | |
| DGS / SGS | ● | | ● | ● | | | |
| DTE | ● | | ● | | ● | | ● |
| New DTM | ● | | ● | ● | ● | | ● |
| DGG | ● | | ● | | | | |
| DGE | ● | | | | | | |
| DTX | ● | ● | ● | ● | ● | ● | ● |
| DTI | | ● | | | | ● | |
| DGIM / DGIS | | ● | | | | | |
| DTF | | | ● | | | | ● |
| DTR | ● | | ● | | ● | | ● |
| DTIU | ● Undercutting | ● Undercutting | | | | | |
| DTA | | | | | ● Al wheel machining | ● Al wheel machining | |
| SGN | ● | | | | | | |

FEATURES OF INSERTS

External grooving and parting

DGM type (2 corners)
SGM type (1 corner)



1st choice for external grooving and parting off

- Smooth chip evacuation
- Well-designed edge with high strength
- Handed insert available

■ Standard feed

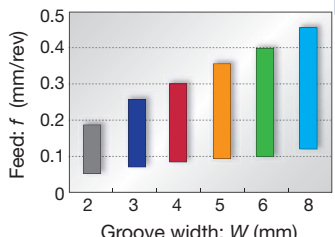

| Groove width: W (mm) | Feed: f (mm/rev) |
|----------------------|------------------|
| 2 | 0.18 |
| 3 | 0.25 |
| 4 | 0.30 |
| 5 | 0.35 |
| 6 | 0.40 |
| 8 | 0.45 |



DGS type (2 corners)
SGS type (1 corner)



Lower cutting force and superior sharpness

- Unique-designed edge and chipbreaker
- Handed insert available

■ Standard feed

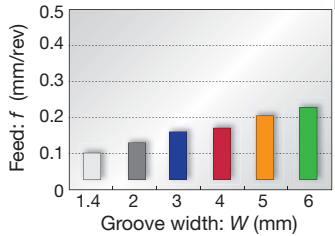

| Groove width: W (mm) | Feed: f (mm/rev) |
|----------------------|------------------|
| 1.4 | 0.10 |
| 2 | 0.12 |
| 3 | 0.15 |
| 4 | 0.18 |
| 5 | 0.20 |
| 6 | 0.22 |

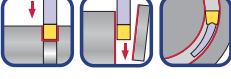

External and face grooving, and turning

DTE type (2 corners)



For general purpose

- Unique chipbreaker makes chips shorter
- Molded and ground insert available

■ Standard feed and DoC

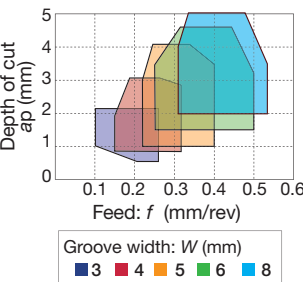

■ Standard feed

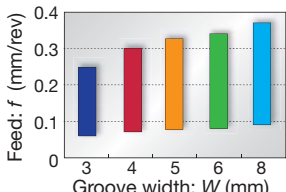

| Groove width: W (mm) | Feed: f (mm/rev) |
|----------------------|------------------|
| 3 | 0.25 |
| 4 | 0.30 |
| 5 | 0.35 |
| 6 | 0.40 |
| 8 | 0.45 |

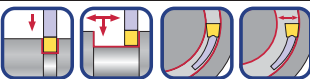

New

DTM type (2 corners)



For general purpose

- First choice chipbreaker for grooving and groove-turning
- General purpose chipbreaker for light to medium cutting of grooving and groove-turning
- Smooth chipbreaking in machining steel, alloy steel, stainless steel, and heat-resistant superalloys

■ Standard feed and DoC

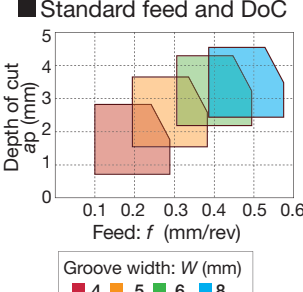

■ Standard feed

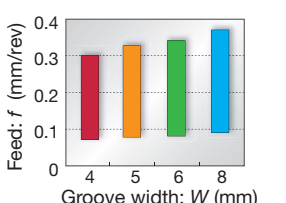

| Groove width: W (mm) | Feed: f (mm/rev) |
|----------------------|------------------|
| 4 | 0.30 |
| 5 | 0.35 |
| 6 | 0.40 |
| 8 | 0.45 |

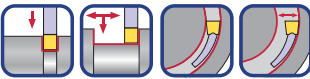

External and face grooving

DGG type (2 corners)



For non-ferrous materials and titanium

- Chipbreaker with low cutting force
- Sharp cutting edge that prevents vibration and delivers fine surface finish

■ Standard feed

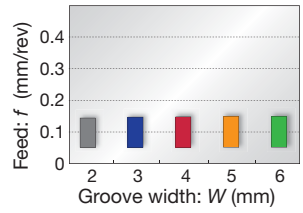

| Groove width: W (mm) | Feed: f (mm/rev) |
|----------------------|------------------|
| 2 | 0.12 |
| 3 | 0.15 |
| 4 | 0.18 |
| 5 | 0.20 |
| 6 | 0.22 |



External, internal and face grooving, and turning

DTX type (2 corners)



Multi-functional type

- Well balanced sharpness and strength
- Multi functional insert

Standard feed and DoC

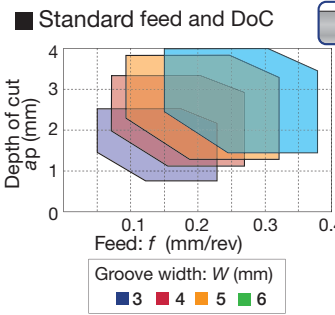

Standard feed

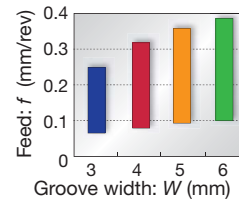

External grooving

DGE type (2 corners)



For high accurate and shallow groove

- Excellent chip control

Standard feed

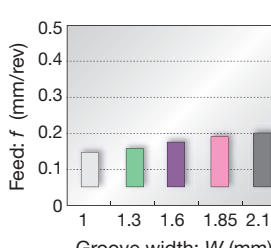

Profiling and undercutting

DTR type (2 corners)

Molded



Ground



Full radius type

- Excellent chip control
- Molded and ground insert available

Standard feed and DoC

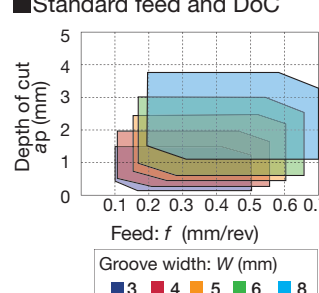

DTIU type (2 corners)



Full radius type

- Excellent chip control
- For undercutting

Standard feed and DoC

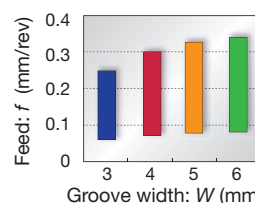

Internal grooving and turning

DTI type (2 corners)



1st choice for internal grooving

- Unique chipbreaker makes chips shorter
- Molded and ground insert available



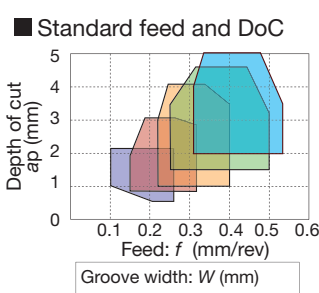

Standard feed and DoC

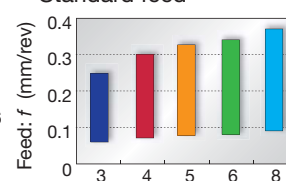

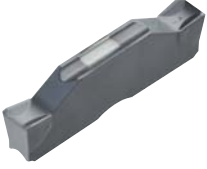
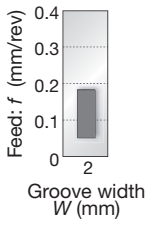

Standard feed

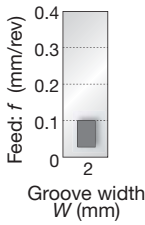

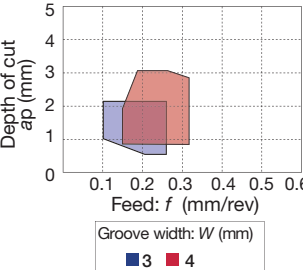
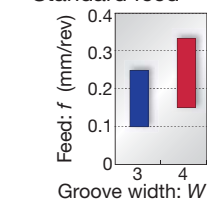

Small diameter internal grooving

| | | |
|---|--|---|
| <p>DGIM type (2 corners)</p>  | <p>2 mm insert width only (For general purpose)</p> <ul style="list-style-type: none"> Unique chipbreaker for excellent chip control Excellent fracture resistance due to optimum land on the cutting edge For general applications on steels & stainless steels | <p>■ Standard feed</p>   |
| <p>DGIS type (2 corners)</p>  | <p>2 mm insert width only (Lower cutting force)</p> <ul style="list-style-type: none"> Low cutting force due to a unique land geometry Applicable for low carbon steels & stainless steels | <p>■ Standard feed</p>   |

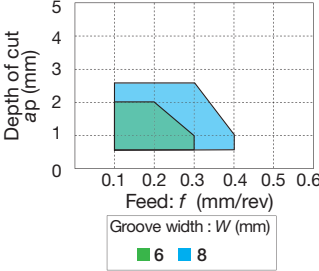

Face grooving and turning

| | | |
|--|--|--|
| <p>DTF type (2 corners)</p>  | <p>1st choice for face grooving</p> <ul style="list-style-type: none"> Unique chipbreaker makes chips shorter Handed insert | <p>■ Standard feed and DoC</p>  <p>■ Standard feed</p>   |
|--|--|--|

Aluminium wheel machining

| | | |
|--|---|---|
| <p>DTA type (2 corners)</p>  | <p>Full radius type</p> <ul style="list-style-type: none"> Excellent chip control For aluminium wheel profiling Ground insert | <p>■ Standard feed and DoC</p>   |
|--|---|---|

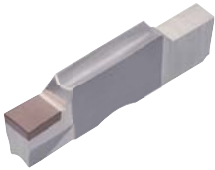
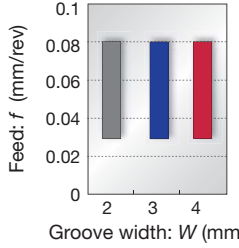
External grooving of hardened steels

| | | |
|---|---|---|
| <p>SGN-CBN type (1 corner)</p>  | <p>For hardened steel cutting</p> <ul style="list-style-type: none"> Optimum cutting edge shape for grooving of hardened steels High tolerance width for finishing ($W = \pm 0.025$ mm) | <p>■ Standard feed</p>   |
|---|---|---|

INSERT

DGM

External grooving and parting off, 2 corner

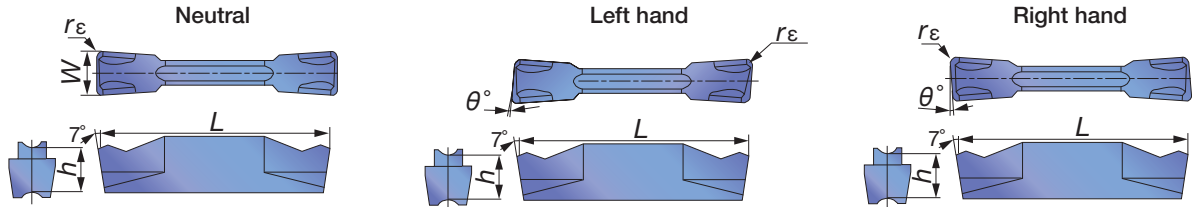

| Designation | Insert seat size | W±0.05 | r _ε | New | | Coated | | | | | | Cermet | | L | h | θ° |
|----------------|------------------|--------|----------------|--------|---|--------|---|-------|---|-------|---|--------|-------|-----|----|----|
| | | | | AH7025 | | AH725 | | AH905 | | GH130 | | NS9530 | | | | |
| | | | | R | L | R | L | R | L | R | L | R | L | | | |
| DGM2-020 | 2 | 2 | 0.2 | ● | ● | ● | | | | | ● | | 20 | 5 | 0 | |
| DGM2-020-6R/L | 2 | 2 | 0.2 | | ● | ● | ● | | | ● | ● | | 19.8 | 5 | 6 | |
| DGM2-020-8R/L | 2 | 2 | 0.2 | | ● | ● | ● | | | ● | ● | | 19.8 | 5 | 8 | |
| DGM2-020-15R/L | 2 | 2 | 0.2 | | ● | ● | ● | | | ● | ● | | 19.8 | 5 | 15 | |
| DGM2-002-15R/L | 2 | 2 | 0.02 | | | ● | ● | | | ● | ● | | 19.35 | 5 | 15 | |
| DGM3-020 | 3 | 3 | 0.2 | ● | ● | ● | | ● | | ● | | ● | 20 | 5 | 0 | |
| DGM3-020-6R/L | 3 | 3 | 0.2 | | ● | ● | ● | | | ● | ● | | 19.9 | 5 | 6 | |
| DGM3-002-6R/L | 3 | 3 | 0.02 | | | ● | ● | | | ● | ● | | 19.45 | 5 | 6 | |
| DGM3-020-15R/L | 3 | 3 | 0.2 | | | ● | ● | | | ● | ● | | 19.9 | 5 | 15 | |
| DGM4-030 | 4 | 4 | 0.3 | ● | ● | ● | | ● | | ● | | ● | 20 | 5 | 0 | |
| DGM4-030-4R/L | 4 | 4 | 0.3 | | ● | ● | ● | | | ● | ● | | 19.8 | 5 | 4 | |
| DGM4-030-15R/L | 4 | 4 | 0.3 | | ● | ● | ● | | | ● | ● | | 19.8 | 5 | 15 | |
| DGM5-030 | 5 | 5 | 0.3 | ● | ● | ● | | ● | | ● | | ● | 25 | 5.5 | 0 | |
| DGM5-030-4R | 5 | 5 | 0.3 | | ● | ● | | | | ● | | | 24.9 | 5.5 | 4 | |
| DGM6-030 | 6 | 6 | 0.3 | ● | ● | ● | | ● | | ● | | | 25 | 5.5 | 0 | |
| DGM8-040 | 8 | 8 | 0.4 | ● | ● | ● | | | | ● | | | 30 | 6.7 | 0 | |

● : New product
● : Line up

SGM

External deep grooving and parting off, 1 corner

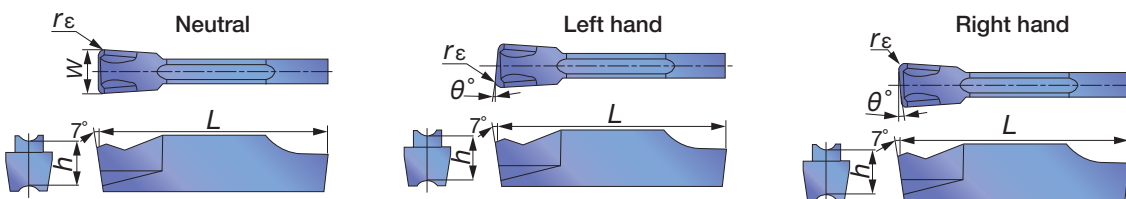

| Designation | Insert seat size | W±0.05 | r _ε | Coated | | | | L | h | θ° |
|----------------|------------------|--------|----------------|--------|---|-------|---|-------|-----|----|
| | | | | AH725 | | GH130 | | | | |
| | | | | R | L | R | L | | | |
| SGM2-020 | 2 | 2 | 0.2 | ● | | ● | | 20 | 5 | 0 |
| SGM2-020-6R/L | 2 | 2 | 0.2 | ● | ● | ● | ● | 19.8 | 5 | 6 |
| SGM3-020 | 3 | 3 | 0.2 | ● | | ● | | 20 | 5 | 0 |
| SGM3-020-6R/L | 3 | 3 | 0.2 | ● | ● | ● | ● | 19.6 | 5 | 6 |
| SGM3-020-15R/L | 3 | 3 | 0.2 | ● | ● | ● | ● | 19.6 | 5 | 15 |
| SGM4-030 | 4 | 4 | 0.3 | ● | | ● | | 20 | 5 | 0 |
| SGM4-030-4R/L | 4 | 4 | 0.3 | ● | ● | ● | ● | 19.65 | 5 | 4 |
| SGM5-030 | 5 | 5 | 0.3 | ● | | ● | | 25 | 5.5 | 0 |
| SGM6-030 | 6 | 6 | 0.3 | ● | | ● | | 25 | 5.5 | 0 |

● : Line up

DGS

External grooving and parting off, 2 corner

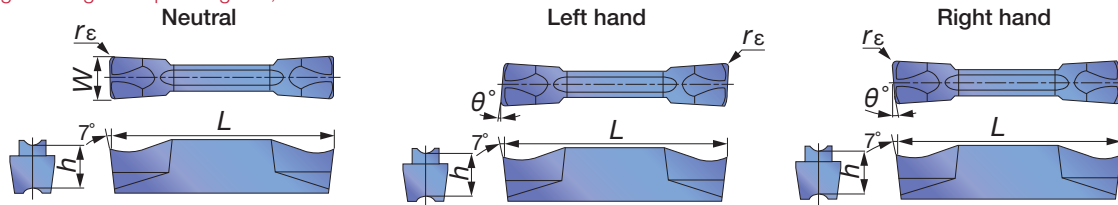

| Designation | Insert seat size | W±0.05 | r _ε | Coated | | | | | | | | Cermet | | L | h | θ° |
|----------------|------------------|--------|----------------|--------|---|--------|---|-------|---|-------|---|--------|---|-------|-----|----|
| | | | | T9125 | | AH7025 | | AH725 | | GH130 | | NS9530 | | | | |
| | | | | R | L | R | L | R | L | R | L | R | L | | | |
| DGS1.4-016 | 1 | 1.4 | 0.16 | | | ● | | ● | | ● | | | | 16 | 4.3 | 0 |
| DGS2-020 | 2 | 2 | 0.2 | ● | | ● | | ● | | ● | | ● | | 20 | 5 | 0 |
| DGS2-020-6R/L | 2 | 2 | 0.2 | | | ● | | ● | ● | ● | | | | 19.95 | 5 | 6 |
| DGS2-002-6R/L | 2 | 2 | 0.02 | | | | | ● | ● | ● | ● | | | 19.8 | 5 | 6 |
| DGS2-020-15R/L | 2 | 2 | 0.2 | | | ● | | ● | ● | ● | ● | | | 19.95 | 5 | 15 |
| DGS2-002-15R/L | 2 | 2 | 0.02 | | | | | ● | ● | ● | ● | | | 19.8 | 5 | 15 |
| DGS3-020 | 3 | 3 | 0.2 | ● | | ● | | ● | | ● | | ● | | 20 | 5 | 0 |
| DGS3-020-6R/L | 3 | 3 | 0.2 | | | ● | | ● | ● | ● | ● | | | 19.9 | 5 | 6 |
| DGS3-002-6R/L | 3 | 3 | 0.02 | | | | | ● | ● | ● | ● | | | 19.6 | 5 | 6 |
| DGS3-020-15R/L | 3 | 3 | 0.2 | | | ● | | ● | ● | ● | ● | | | 19.9 | 5 | 15 |
| DGS3-002-15R/L | 3 | 3 | 0.02 | | | | | ● | ● | ● | ● | | | 19.45 | 5 | 15 |
| DGS4-030 | 4 | 4 | 0.3 | ● | | ● | | ● | | ● | | ● | | 20 | 5 | 0 |
| DGS4-030-4R/L | 4 | 4 | 0.3 | | | ● | | ● | ● | ● | ● | | | 19.8 | 5 | 4 |
| DGS5-030 | 5 | 5 | 0.3 | ● | | ● | | ● | | ● | | ● | | 25 | 5.5 | 0 |
| DGS6-030 | 6 | 6 | 0.3 | ● | | ● | | ● | | ● | | ● | | 25 | 5.5 | 0 |

● : New product
● : Line up

Caution

| Designation | øDmax (mm) | Designation | øDmax (mm) |
|----------------|------------|----------------|------------|
| DGM2-002-15R/L | 28 | DGS2-002-15R/L | 28 |
| DGM3-002-15R/L | 29 | DGS3-002-15R/L | 29 |
| DGM4-030-15R/L | 30 | SGS3-020-15R/L | 103 |
| SGM3-020-15R/L | 103 | SGS3-002-15R/L | 34 |

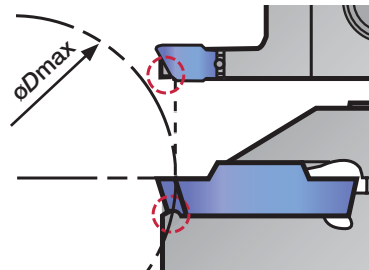

SGS

External deep grooving and parting off, 1 corner

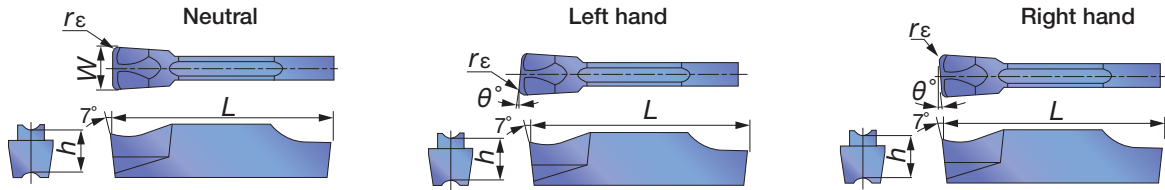

| Designation | Insert seat size | W±0.05 | r _ε | Coated | | | | L | h | θ° |
|----------------|------------------|--------|----------------|--------|---|-------|---|-------|-----|----|
| | | | | AH725 | | GH130 | | | | |
| | | | | R | L | R | L | | | |
| SGS2-020 | 2 | 2 | 0.2 | ● | | ● | | 20 | 5 | 0 |
| SGS2-020-6R/L | 2 | 2 | 0.2 | ● | ● | ● | ● | 19.8 | 5 | 6 |
| SGS2-020-15R/L | 2 | 2 | 0.2 | ● | ● | ● | ● | 19.8 | 5 | 15 |
| SGS3-020 | 3 | 3 | 0.2 | | ● | | ● | 20 | 5 | 0 |
| SGS3-020-6R/L | 3 | 3 | 0.2 | ● | ● | ● | ● | 19.64 | 5 | 6 |
| SGS3-002-6R/L | 3 | 3 | 0.02 | ● | ● | ● | ● | 19.8 | 5 | 6 |
| SGS3-020-15R/L | 3 | 3 | 0.2 | ● | ● | ● | ● | 19.64 | 5 | 15 |
| SGS3-002-15R/L | 3 | 3 | 0.02 | ● | ● | ● | ● | 19.8 | 5 | 15 |
| SGS4-030 | 4 | 4 | 0.3 | | ● | | ● | 20 | 5 | 0 |
| SGS5-030 | 5 | 5 | 0.3 | | ● | | ● | 25 | 5.5 | 0 |
| SGS6-030 | 6 | 6 | 0.3 | | ● | | ● | 25 | 5.5 | 0 |

● : Line up

DGE

External grooving (for high-precision machining)

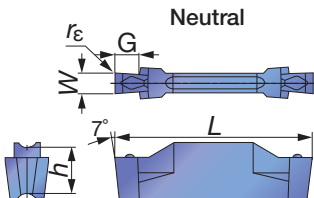

| Designation | Insert seat size | W±0.02 | r _ε | Coated | | | Cermet | G | L | h | |
|-------------|------------------|--------|----------------|--------|---|-------|--------|----|---|---|--------|
| | | | | AH725 | | GH130 | | | | | NS9530 |
| | | | | ● | ● | ● | | | | | ● |
| DGE100-000 | 2 | 1 | 0 | ● | ● | ● | 2.5 | 20 | 5 | | |
| DGE130-000 | 2 | 1.3 | 0 | ● | ● | ● | 2.5 | 20 | 5 | | |
| DGE160-010 | 2 | 1.6 | 0.1 | ● | ● | ● | 2.5 | 20 | 5 | | |
| DGE185-010 | 2 | 1.85 | 0.1 | ● | ● | ● | 3.5 | 20 | 5 | | |
| DGE215-015 | 2 | 2.15 | 0.15 | ● | ● | ● | 3.5 | 20 | 5 | | |

● : Line up

Caution

øD_{max} is limited as shown in the picture to the right according to the groove depth, G.D. Please refer to the following table.

G.D = Groove depth

| Designation | Max. groove depth (mm) | øD _{max} (mm) | | | | |
|-------------|------------------------|------------------------|------------|----------|------------|----------|
| | | G.D. = 1 | G.D. = 1.5 | G.D. = 2 | G.D. = 2.5 | G.D. = 3 |
| DGE100-000 | 2 | ∞ | 18.6 | 11.5 | - | - |
| DGE130-000 | | | | | - | - |
| DGE160-010 | | | | | - | - |
| DGE185-010 | 3 | ∞ | 18.6 | 11.5 | 8.8 | 7 |
| DGE215-015 | | | | | 8.8 | 7 |

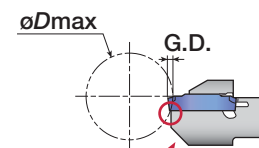

Relevant area (Interference)

DTE

External, face grooving and turning (for high-precision machining)

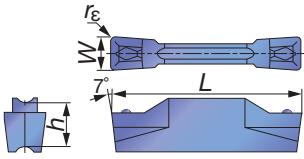

| Designation | Insert seat size | W \pm 0.02 | r _e | Coated | | | | Cermet | L | h |
|-------------|------------------|--------------|----------------|--------|--------|-------|-------|--------|----|-----|
| | | | | T9125 | AH7025 | AH725 | GH130 | NS9530 | | |
| DTE265-015 | 3 | 2.65 | 0.15 | ● | ● | ● | ● | ● | 20 | 5 |
| DTE300-020 | 3 | 3 | 0.2 | ● | ● | ● | ● | ● | 20 | 5 |
| DTE300-040 | 3 | 3 | 0.4 | ● | | ● | ● | ● | 20 | 5 |
| DTE315-015 | 3 | 3.15 | 0.15 | ● | | ● | ● | ● | 20 | 5 |
| DTE400-040 | 4 | 4 | 0.4 | ● | | ● | ● | ● | 20 | 5 |
| DTE400-080 | 4 | 4 | 0.8 | ● | ● | ● | ● | ● | 20 | 5 |
| DTE415-015 | 4 | 4.15 | 0.15 | ● | | ● | ● | ● | 20 | 5 |
| DTE478-055 | 5 | 4.78 | 0.55 | ● | | ● | ● | ● | 25 | 5.5 |
| DTE500-040 | 5 | 5 | 0.4 | ● | | ● | ● | ● | 25 | 5.5 |
| DTE500-080 | 5 | 5 | 0.8 | ● | ● | ● | ● | ● | 25 | 5.5 |
| DTE515-015 | 5 | 5.15 | 0.15 | ● | | ● | ● | | 25 | 5.5 |
| DTE600-080 | 6 | 6 | 0.8 | ● | ● | ● | ● | | 25 | 5.5 |
| DTE600-120 | 6 | 6 | 1.2 | ● | | ● | ● | | 25 | 5.5 |
| DTE800-080 | 8 | 8 | 0.8 | ● | | ● | ● | | 30 | 6.7 |
| DTE800-120 | 8 | 8 | 1.2 | ● | | ● | ● | | 30 | 6.7 |

● : Line up

DTE

External, face grooving and turning

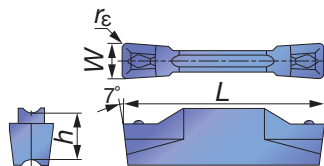

| Designation | Insert seat size | W \pm 0.05 | r _e | Coated | | | | Cermet | L | L |
|-------------|------------------|--------------|----------------|--------|--------|-------|-------|--------|----|---|
| | | | | T9125 | AH7025 | AH725 | GH130 | NS9530 | | |
| DTE3-040 | 3 | 3 | 0.4 | ● | ● | ● | ● | ● | 20 | 5 |
| DTE4-040 | 4 | 4 | 0.4 | ● | ● | ● | ● | ● | 20 | 5 |

● : Line up

DTM **New**

External, internal, face grooving and turning

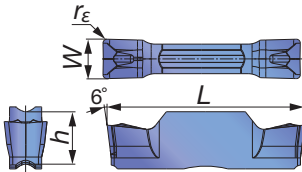

| Designation | Insert seat size | W±0.05 | r _ε | New | | L | h |
|-------------|------------------|--------|----------------|------------------|------------------|----|-----|
| | | | | Coated AH7025 | Cermet NS9530 | | |
| DTM4-040 | 4 | 4 | 0.4 | ● | | 20 | 5 |
| DTM4-080 | 4 | 4 | 0.8 | ● | | 20 | 5 |
| DTM5-080 | 5 | 5 | 0.8 | ● | | 25 | 5.5 |
| DTM6-080 | 6 | 6 | 0.8 | ● | | 25 | 5.5 |
| DTM8-080 | 8 | 8 | 0.8 | ● | | 30 | 6.7 |

● : New product

DGG

External and face grooving (for high-precision machining)

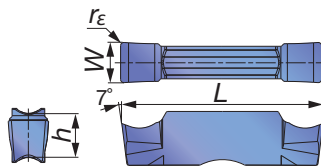

| Designation | Insert seat size | W±0.02 | r _ε | Coated | Uncoated | L | h |
|-------------|------------------|--------|----------------|--------|----------|----|-----|
| | | | | NS9530 | KS05F | | |
| DGG200-020 | 2 | 2 | 0.2 | ● | ● | 20 | 5 |
| DGG300-020 | 3 | 3 | 0.2 | ● | ● | 20 | 5 |
| DGG400-040 | 4 | 4 | 0.4 | ● | ● | 20 | 5 |
| DGG500-040 | 5 | 5 | 0.4 | ● | ● | 25 | 5.5 |
| DGG600-040 | 6 | 6 | 0.4 | ● | ● | 25 | 5.5 |

● : Line up

DTX

External, internal, face grooving and turning

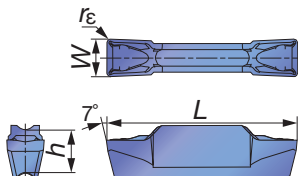

| Designation | Insert seat size | W±0.05 | r _ε | Coated | | | | Cermet | L | h |
|-------------|------------------|--------|----------------|--------|--------|-------|-------|--------|----|-----|
| | | | | T9125 | AH7025 | AH725 | GH130 | NS9530 | | |
| DTX3-030 | 3 | 3 | 0.3 | ● | ● | ● | ● | ● | 20 | 5 |
| DTX4-040 | 4 | 4 | 0.4 | ● | ● | ● | ● | ● | 20 | 5 |
| DTX5-040 | 5 | 5 | 0.4 | ● | ● | ● | ● | ● | 25 | 5.5 |
| DTX6-080 | 6 | 6 | 0.8 | | | ● | ● | | 25 | 5.5 |

● : Line up

DTF

Face grooving and turning

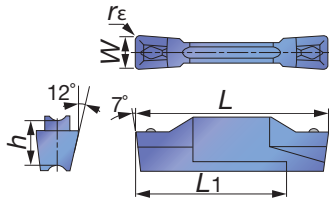

Right hand (R) shown.

| Designation | Insert seat size | $W \pm 0.05$ | r_ϵ | Coated | | | | | | Cermet | | L | h | L_1 |
|--------------|------------------|--------------|--------------|--------|---|-------|---|-------|---|--------|----|-----|-----|-------|
| | | | | T9125 | | AH725 | | GH130 | | NS9530 | | | | |
| | | | | R | L | R | L | R | L | R | L | | | |
| DTF3-040-R/L | 3 | 3 | 0.4 | ● | ● | ● | ● | ● | ● | ● | 20 | 5 | 16 | |
| DTF4-040-R/L | 4 | 4 | 0.4 | ● | ● | ● | ● | ● | ● | ● | 20 | 5 | 16 | |

● : Line up

DTI

Internal grooving and turning (for high-precision machining)

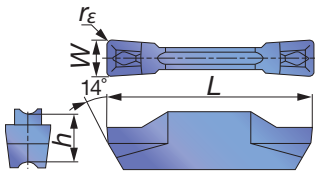

| Designation | Insert seat size | $W \pm 0.02$ | r_ϵ | Coated | | | Cermet | L | h |
|-------------|------------------|--------------|--------------|--------|-------|-------|--------|-----|-----|
| | | | | T9125 | AH725 | GH130 | NS9530 | | |
| DTI300-040 | 3 | 3 | 0.4 | ● | ● | ● | ● | 20 | 5 |
| DTI400-040 | 4 | 4 | 0.4 | ● | ● | ● | ● | 20 | 5 |
| DTI400-080 | 4 | 4 | 0.8 | ● | ● | ● | ● | 20 | 5 |
| DTI500-040 | 5 | 5 | 0.4 | ● | ● | ● | ● | 25 | 5.5 |
| DTI500-080 | 5 | 5 | 0.8 | ● | ● | ● | ● | 25 | 5.5 |
| DTI600-080 | 6 | 6 | 0.8 | ● | ● | ● | ● | 25 | 5.5 |
| DTI600-120 | 6 | 6 | 1.2 | ● | ● | ● | ● | 25 | 5.5 |
| DTI800-080 | 8 | 8 | 0.8 | ● | ● | ● | ● | 30 | 6.7 |
| DTI800-120 | 8 | 8 | 1.2 | ● | ● | ● | ● | 30 | 6.7 |

● : Line up

DTI

Internal grooving and turning

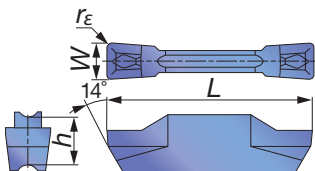

| Designation | Insert seat size | $W \pm 0.05$ | r_ϵ | Coated | | | | Cermet | L | h |
|-------------|------------------|--------------|--------------|--------|--------|-------|-------|--------|-----|-----|
| | | | | T9125 | AH7025 | AH725 | GH130 | NS9530 | | |
| DTI3-040 | 3 | 3 | 0.4 | ● | ● | ● | ● | ● | 20 | 5 |
| DTI4-040 | 4 | 4 | 0.4 | ● | ● | ● | ● | ● | 20 | 5 |

● : Line up

DGIM

Small diameter internal grooving

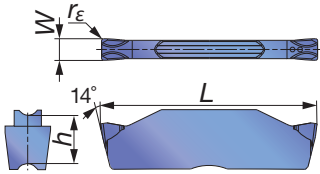

| Designation | Insert seat size | W±0.05 | r _ε | Coated | | | Cermet | L | h |
|-------------|------------------|--------|----------------|--------|-------|-------|--------|----|---|
| | | | | T9125 | AH725 | GH130 | NS9530 | | |
| DGIM2-020 | 2 | 2 | 0.2 | ● | ● | ● | ● | 20 | 5 |

● : Line up

DGIS

Small diameter internal grooving

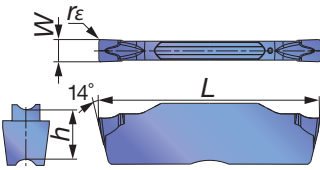

| Designation | Insert seat size | W±0.05 | r _ε | Coated | | | Cermet | L | h |
|-------------|------------------|--------|----------------|--------|-------|-------|--------|----|---|
| | | | | T9125 | AH725 | GH130 | NS9530 | | |
| DGIS2-020 | 2 | 2 | 0.2 | ● | ● | ● | ● | 20 | 5 |

● : Line up

DTR

Profiling and undercutting (for high-precision machining)

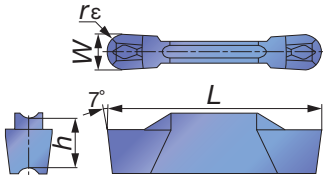

| Designation | Insert seat size | W±0.02 | r _ε | Coated | | | Cermet | L | h |
|-------------|------------------|--------|----------------|--------|-------|-------|--------|----|-----|
| | | | | T9125 | AH725 | GH130 | NS9530 | | |
| DTR300-150 | 3 | 3 | 1.5 | ● | ● | ● | ● | 20 | 5 |
| DTR400-200 | 4 | 4 | 2 | ● | ● | ● | ● | 20 | 5 |
| DTR478-239 | 5 | 4.78 | 2.39 | ● | ● | ● | ● | 25 | 5.5 |
| DTR500-250 | 5 | 5 | 2.5 | ● | ● | ● | ● | 25 | 5.5 |
| DTR600-300 | 6 | 6 | 3 | ● | ● | ● | | 25 | 5.5 |

● : Line up

DTR

Profiling and undercutting

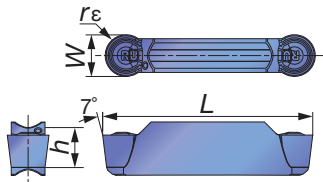

| Designation | Insert seat size | W±0.05 | r _ε | Coated | | | | | Cermet | L | h |
|-------------|------------------|--------|----------------|--------|--------|-------|-------|-------|--------|----|-----|
| | | | | T9125 | AH7025 | AH725 | AH905 | GH130 | NS9530 | | |
| DTR3-150 | 3 | 3 | 1.5 | ● | ● | ● | ● | ● | ● | 20 | 5 |
| DTR4-200 | 4 | 4 | 2 | ● | ● | ● | ● | ● | ● | 20 | 5 |
| DTR5-250 | 5 | 5 | 2.5 | ● | ● | ● | ● | ● | ● | 25 | 5.5 |
| DTR6-300 | 6 | 6 | 3 | ● | ● | ● | | ● | | 25 | 5.5 |
| DTR8-400 | 8 | 8 | 4 | ● | | ● | | ● | | 30 | 6.7 |

● : Line up

DTIU

Profiling and undercutting (for high-precision machining)

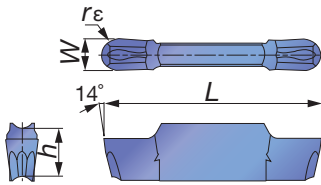

| Designation | Insert seat size | W±0.02 | r _ε | Coated | | L | h |
|-------------|------------------|--------|----------------|--------|-------|----|-----|
| | | | | AH725 | GH130 | | |
| DTIU300-150 | 3 | 3 | 1.5 | ● | ● | 20 | 5 |
| DTIU400-200 | 4 | 4 | 2 | ● | ● | 20 | 5 |
| DTIU500-250 | 5 | 5 | 2.5 | ● | ● | 25 | 5.5 |
| DTIU600-300 | 6 | 6 | 3 | ● | ● | 25 | 5.5 |

● : Line up

DTA

Aluminium wheel machining (for high-precision machining)

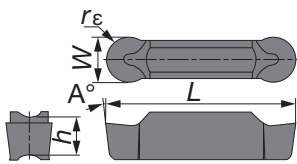

| Designation | Insert seat size | W±0.02 | r _ε | Uncoated | L | h | A° |
|-------------|------------------|--------|----------------|----------|----|-----|----|
| | | | | TH10 | | | |
| DTA600-300 | 6 | 6 | 3 | ● | 25 | 5.5 | 7 |
| DTA800-400 | 8 | 8 | 4 | ● | 30 | 6.7 | 10 |

● : Line up

SGN

External grooving of hardened steels

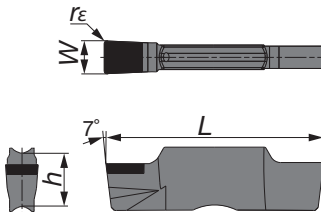

| Designation | Insert seat size | W±0.025 | r _ε | CBN | L | h |
|-------------|------------------|---------|----------------|-------|----|---|
| | | | | BX360 | | |
| SGN200-020 | 2 | 2 | 0.2 | ● | 20 | 5 |
| SGN300-020 | 3 | 3 | 0.2 | ● | 20 | 5 |
| SGN400-020 | 4 | 4 | 0.2 | ● | 20 | 5 |

● : Line up

New

CTER/L-CHP

External toolholders for grooving, parting & turning, with channels for high pressure coolant

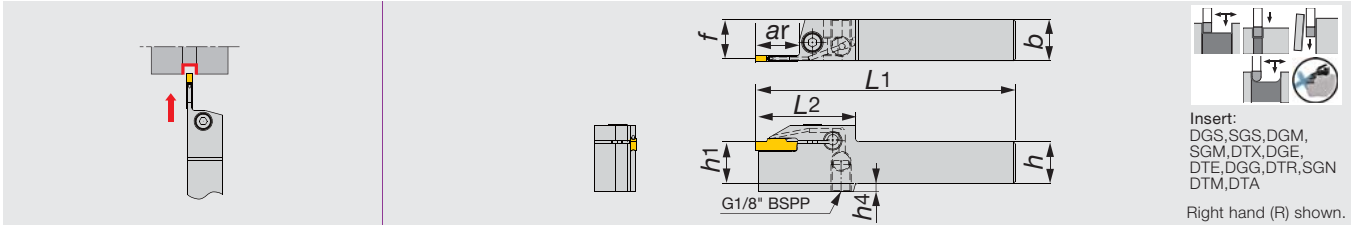

Insert:
DGS, SGS, DGM,
SGM, DTX, DGE,
DTE, DGG, DTR, SGN
DTM, DTA
Right hand (R) shown.

| Designation | W | Seat size | ar | h ₁ | b | h | L ₁ | f | h ₄ | L ₂ | Torque* |
|---------------------|---|-----------|----|----------------|----|----|----------------|-------|----------------|----------------|---------|
| CTER/L2020-2T17-CHP | 2 | 2 | 17 | 20 | 20 | 20 | 125 | 19.1 | 4 | 45 | 5.5 |
| CTER/L2525-2T17-CHP | 2 | 2 | 17 | 25 | 25 | 25 | 150 | 24.1 | - | 45 | 5.5 |
| CTER/L2020-3T20-CHP | 3 | 3 | 20 | 20 | 20 | 20 | 125 | 18.8 | 4 | 48 | 5.5 |
| CTER/L2525-3T20-CHP | 3 | 3 | 20 | 25 | 25 | 25 | 150 | 23.8 | - | 48 | 5.5 |
| CTER/L2525-3T25-CHP | 3 | 3 | 25 | 25 | 25 | 25 | 150 | 23.8 | - | 51 | 5.5 |
| CTER/L2525-4T25-CHP | 4 | 4 | 25 | 25 | 25 | 25 | 150 | 23.5 | - | 55 | 8 |
| CTER/L2525-5T20-CHP | 5 | 5 | 20 | 25 | 25 | 25 | 150 | 23.08 | - | 49 | 8 |
| CTER/L2525-6T20-CHP | 6 | 6 | 20 | 25 | 25 | 25 | 150 | 22.58 | 7 | 52 | 12 |

- When the groove depth is more than 1.5 mm less than the total insert length, use 1-cornered insert.
- *Torque: Recommended torque (N-m) for clamping

To be released in 2018

SPARE PARTS



| Designation | Clamping screw | Wrench |
|---------------------|----------------|--------|
| CTER/L2020-2T17-CHP | CM5x0.8x20-A | P-4 |
| CTER/L2525-2T17-CHP | CM5x0.8x25-A | P-4 |
| CTER/L2020-3T20-CHP | CM5x0.8x20-A | P-4 |
| CTER/L2525-3T20-CHP | CM5x0.8x25-A | P-4 |
| CTER/L2525-3T25-CHP | CM5x0.8x25-A | P-4 |
| CTER/L2525-4T25-CHP | CM6x1x25-A | P-5 |
| CTER/L2525-5T20-CHP | CM6x1x25-A | P-5 |
| CTER/L2525-6T20-CHP | CM8x1.25x25-A | P-6 |

- See pages 43 for tube connections

CTER/L

External toolholders for grooving, parting & turning

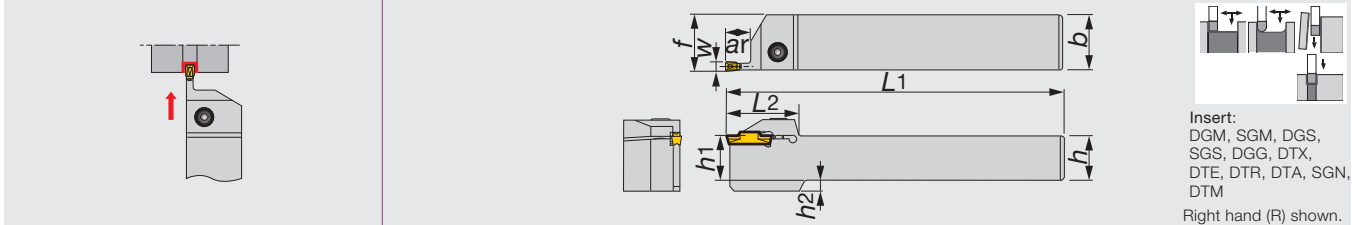

| Designation | W | Seat size | ar | h | b | L ₁ | L ₂ | h ₁ | f ⁽¹⁾ | h ₂ |
|-----------------|---|-----------|----|----|----|----------------|----------------|----------------|------------------|----------------|
| CTER/L1616-2T08 | 2 | 2 | 8 | 16 | 16 | 110 | 33 | 16 | 16.1 | 4 |
| CTER/L2020-2T08 | 2 | 2 | 8 | 20 | 20 | 125 | 33 | 20 | 20.1 | - |
| CTER/L2525-2T08 | 2 | 2 | 8 | 25 | 25 | 150 | 33 | 25 | 25.1 | - |
| CTER/L1616-2T12 | 2 | 2 | 12 | 16 | 16 | 110 | 32 | 16 | 16.1 | 4 |
| CTER/L2020-2T12 | 2 | 2 | 12 | 20 | 20 | 125 | 32 | 20 | 20.1 | - |
| CTER/L2525-2T12 | 2 | 2 | 12 | 25 | 25 | 150 | 32 | 25 | 25.1 | - |
| CTER/L1616-2T17 | 2 | 2 | 17 | 16 | 16 | 110 | 37 | 16 | 16.1 | 4 |
| CTER/L2020-2T17 | 2 | 2 | 17 | 20 | 20 | 125 | 37 | 20 | 20.1 | - |
| CTER/L2525-2T17 | 2 | 2 | 17 | 25 | 25 | 150 | 37 | 25 | 25.1 | - |
| CTER/L1616-3T09 | 3 | 3 | 9 | 16 | 16 | 110 | 32 | 16 | 16.3 | 4 |
| CTER/L2020-3T09 | 3 | 3 | 9 | 20 | 20 | 125 | 32 | 20 | 20.3 | - |
| CTER/L2525-3T09 | 3 | 3 | 9 | 25 | 25 | 150 | 32 | 25 | 25.3 | - |
| CTER/L2020-3T12 | 3 | 3 | 12 | 20 | 20 | 125 | 32 | 20 | 20.3 | - |
| CTER/L2525-3T12 | 3 | 3 | 12 | 25 | 25 | 150 | 32 | 25 | 25.3 | - |
| CTER/L1616-3T20 | 3 | 3 | 20 | 16 | 16 | 110 | 38.5 | 16 | 16.3 | 4 |
| CTER/L2020-3T20 | 3 | 3 | 20 | 20 | 20 | 125 | 38.5 | 20 | 20.3 | - |
| CTER/L2525-3T20 | 3 | 3 | 20 | 25 | 25 | 150 | 38.5 | 25 | 25.3 | - |
| CTER/L2525-3T25 | 3 | 3 | 25 | 25 | 25 | 150 | 44.5 | 25 | 25.3 | - |
| CTER/L1616-4T10 | 4 | 4 | 10 | 16 | 16 | 110 | 32 | 16 | 16.5 | 4 |
| CTER/L2020-4T10 | 4 | 4 | 10 | 20 | 20 | 125 | 32 | 20 | 20.5 | - |
| CTER/L2525-4T10 | 4 | 4 | 10 | 25 | 25 | 150 | 32 | 25 | 25.5 | - |
| CTER/L2020-4T15 | 4 | 4 | 15 | 20 | 20 | 125 | 33 | 20 | 20.5 | - |
| CTER/L2525-4T15 | 4 | 4 | 15 | 25 | 25 | 150 | 33 | 25 | 25.5 | - |
| CTER/L1616-4T25 | 4 | 4 | 25 | 16 | 16 | 110 | 45 | 16 | 16.5 | 4 |
| CTER/L2020-4T25 | 4 | 4 | 25 | 20 | 20 | 125 | 45 | 20 | 20.5 | - |
| CTER/L2525-4T25 | 4 | 4 | 25 | 25 | 25 | 150 | 45 | 25 | 25.5 | - |
| CTER/L3232-4T25 | 4 | 4 | 25 | 32 | 32 | 170 | 45 | 32 | 32.5 | - |
| CTER/L2020-5T12 | 5 | 5 | 12 | 20 | 20 | 125 | 37 | 20 | 20.6 | - |
| CTER/L2525-5T12 | 5 | 5 | 12 | 25 | 25 | 150 | 37 | 25 | 25.6 | - |
| CTER/L2525-5T20 | 5 | 5 | 20 | 25 | 25 | 150 | 37 | 25 | 25.6 | - |
| CTER/L2525-5T32 | 5 | 5 | 32 | 25 | 25 | 150 | 56 | 25 | 25.6 | - |
| CTER/L3232-5T32 | 5 | 5 | 32 | 32 | 32 | 170 | 56 | 32 | 32.6 | - |
| CTER/L2020-6T12 | 6 | 6 | 12 | 20 | 20 | 125 | 37 | 20 | 20.6 | - |
| CTER/L2525-6T12 | 6 | 6 | 12 | 25 | 25 | 150 | 37 | 25 | 25.6 | 7 |
| CTER/L2525-6T20 | 6 | 6 | 20 | 25 | 25 | 150 | 41 | 25 | 25.6 | 7 |
| CTER/L2525-6T32 | 6 | 6 | 32 | 25 | 25 | 150 | 56 | 25 | 25.6 | 7 |
| CTER/L3232-6T32 | 6 | 6 | 32 | 32 | 32 | 170 | 56 | 32 | 32.6 | - |
| CTER/L2525-8T16 | 8 | 8 | 16 | 25 | 25 | 150 | 47 | 25 | 26.1 | 7 |
| CTER/L2525-8T25 | 8 | 8 | 25 | 25 | 25 | 150 | 47 | 25 | 26.1 | 7 |
| CTER/L3232-8T25 | 8 | 8 | 25 | 32 | 32 | 170 | 47 | 32 | 33.1 | - |
| CTER/L2525-8T36 | 8 | 8 | 36 | 25 | 25 | 150 | 60 | 25 | 26.1 | 7 |
| CTER/L3232-8T36 | 8 | 8 | 36 | 32 | 32 | 170 | 60 | 32 | 33.1 | - |

When the groove depth is more than 1.5 mm less than the total insert length, use 1-cornered insert.

(1) The value for "f" is true when the insert with the width, indicated in "W" in the table is mounted.

• For applicable inserts, see pages 16-24.

SPARE PARTS



| Designation | Clamping screw | Wrench |
|------------------|----------------|--------|
| CTER/L1616-2T08 | CM5X0.8X16-A | P-4 |
| CTER/L2020-2T08 | CM5X0.8X20-A | P-4 |
| CTELR/L2525-2T08 | CM5X0.8X25-A | P-4 |
| CTER/L1616-2T12 | CM5X0.8X16-A | P-4 |
| CTER/L2020-2T12 | CM5X0.8X20-A | P-4 |
| CTER/L2525-2T12 | CM5X0.8X25-A | P-4 |
| CTER/L1616-2T17 | CM5X0.8X16-A | P-4 |
| CTER/L2020-2T17 | CM5X0.8X20-A | P-4 |
| CTER/L2525-2T17 | CM5X0.8X25-A | P-4 |
| CTER/L1616-3T09 | CM5X0.8X16-A | P-4 |
| CTER/L2020-3T09 | CM5X0.8X20-A | P-4 |
| CTER/L2525-3T09 | CM5X0.8X25-A | P-4 |
| CTER/L2020-3T12 | CM5X0.8X20-A | P-4 |
| CTER/L2525-3T12 | CM5X0.8X25-A | P-4 |
| CTER/L1616-3T20 | CM5X0.8X16-A | P-4 |
| CTER/L2020-3T20 | CM5X0.8X20-A | P-4 |
| CTER/L2525-3T20 | CM5X0.8X25-A | P-4 |
| CTER/L2525-3T25 | CM5X0.8X25-A | P-4 |
| CTER/L1616-4T10 | CM6X1X16-A | P-5 |
| CTER/L2020-4T10 | CM6X1X20-A | P-5 |
| CTER/L2525-4T10 | CM6X1X25-A | P-5 |
| CTER/L2020-4T15 | CM6X1X20-A | P-5 |
| CTER/L2525-4T15 | CM6X1X25-A | P-5 |
| CTER/L1616-4T25 | CM6X1X16-A | P-5 |
| CTER/L2020-4T25 | CM6X1X20-A | P-5 |
| CTER/L2525-4T25 | CM6X1X25-A | P-5 |
| CTER/L3232-4T25 | CM6X1X25-A | P-5 |
| CTER/L2020-5T12 | CM6X1X20-A | P-5 |
| CTER/L2525-5T20 | CM6X1X25-A | P-5 |
| CTER/L2525-5T32 | CM6X1X25-A | P-5 |
| CTER/L3232-5T32 | CM6X1X25-A | P-5 |
| CTER/L2020-6T12 | CM8X1.25X20-A | P-6 |
| CTER/L2525-6T12 | CM8X1.25X25-A | P-6 |
| CTER/L2525-6T20 | CM8X1.25X25-A | P-6 |
| CTER/L2525-6T32 | CM8X1.25X25-A | P-6 |
| CTER/3232-6T32 | CM8X1.25X25-A | P-6 |
| CTER/L2525-8T16 | CM8X1.25X25-A | P-6 |
| CTER/L2525-8T25 | CM8X1.25X25-A | P-6 |
| CTER/L3232-8T25 | CM8X1.25X25-A | P-6 |
| CTER/L2525-8T36 | CM8X1.25X25-A | P-6 |
| CTER/L3232-8T36 | CM8X1.25X25-A | P-6 |

CTEFR/L

Toolholders for External / Face grooving & turning

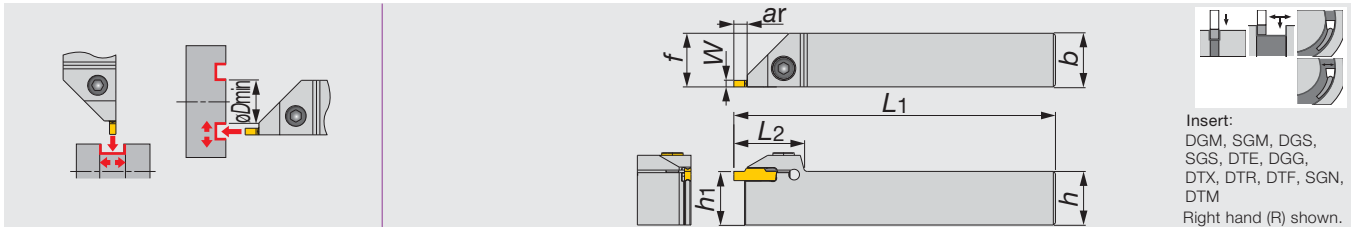

| Designation | W | Seat size | ar | h ₁ | b | h | L ₁ | f ⁽¹⁾ | L ₂ |
|------------------|---|-----------|-----|----------------|----|----|----------------|------------------|----------------|
| CTEFR/L2020-4T04 | 4 | 2, 3, 4 | 4.8 | 20 | 20 | 20 | 125 | 20.5 | 33 |
| CTEFR/L2525-4T04 | 4 | 2, 3, 4 | 4.8 | 25 | 25 | 25 | 150 | 25.5 | 33 |
| CTEFR/L2020-6T04 | 6 | 5, 6 | 4.8 | 20 | 20 | 20 | 125 | 20.6 | 37 |
| CTEFR/L2525-6T04 | 6 | 5, 6 | 4.8 | 25 | 25 | 25 | 150 | 25.6 | 37 |

(1) The value for "f" is true when the insert with the width, indicated in "W" in the table is mounted.

• For applicable inserts, see pages 16-24.

SPARE PARTS



| Designation | Clamping screw | Wrench |
|------------------|----------------|--------|
| CTEFR/L2020-4T04 | CM6X1X20-A | P-5 |
| CTEFR/L2525-4T04 | CM6X1X25-A | P-5 |
| CTEFR/L2020-6T04 | CM6X1X20-A | P-5 |
| CTEFR/L2525-6T04 | CM6X1X25-A | P-5 |

| Insert | Groove width | | Min. dia. for face grooving øD _{min} |
|-----------------|--------------|--|---|
| | W | | |
| DGM / DGS / SGN | 2 | | 295 |
| DGM / DGS / SGN | 3 | | 92 |
| DGM / DGS / SGN | 4 | | 37 |
| DGM / DGS | 5 | | 60 |
| DGM / DGS | 6 | | 57 |
| DTE / DGG | 3 | | 62 |
| DTE / DGG / DTM | 4 | | 42 |
| DTE / DGG / DTM | 5 | | 64 |
| DTE / DGG / DTM | 6 | | 61 |

| Insert | Groove width | | Min. dia. for face grooving øD _{min} |
|--------|--------------|--|---|
| | W | | |
| DTR | 3 | | 44 |
| DTR | 4 | | 32 |
| DTR | 5 | | 48 |
| DTR | 6 | | 48 |
| DTX | 3 | | 19 |
| DTX | 4 | | 20 |
| DTX | 5 | | 20 |
| DTX | 6 | | 23 |
| DTF | 3 | | 19 |
| DTF | 4 | | 20 |

CGEUR/L

External 45° toolholders for undercutting

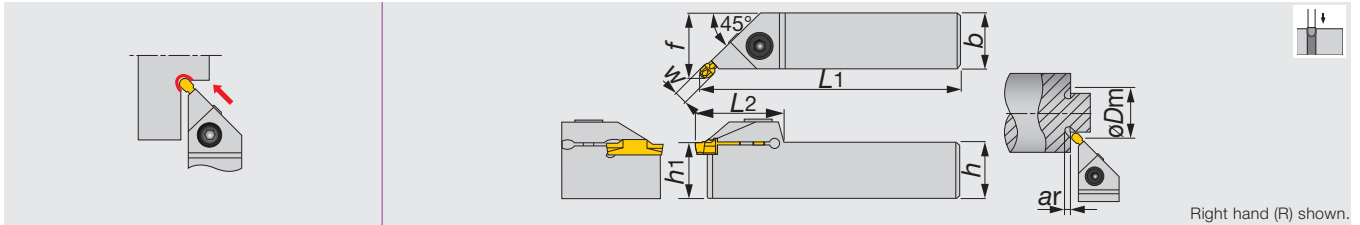

| Designation | W | øD _m | Seat size | a _r | h | b | L ₁ | L ₂ | h ₁ | f ⁽¹⁾ | Insert |
|------------------|---|-----------------|-----------|----------------|----|----|----------------|----------------|----------------|------------------|---------|
| CGEUR/L1616-3T02 | 3 | 32 | 3 | 2.8 | 16 | 16 | 110 | 30 | 16 | 19.3 | DTIU... |
| CGEUR/L2020-3T02 | 3 | 32 | 3 | 2.8 | 20 | 20 | 125 | 30 | 20 | 23.3 | DTIU... |
| CGEUR/L2525-3T02 | 3 | 32 | 3 | 2.8 | 25 | 25 | 150 | 30 | 25 | 28.3 | DTIU... |
| CGEUR/L1616-4T02 | 4 | 32 | 4 | 2.8 | 16 | 16 | 110 | 31 | 16 | 19.5 | DTIU... |
| CGEUR/L2020-4T02 | 4 | 32 | 4 | 2.8 | 20 | 20 | 125 | 31 | 20 | 23.5 | DTIU... |
| CGEUR/L2525-4T02 | 4 | 32 | 4 | 2.8 | 25 | 25 | 150 | 31 | 25 | 28.5 | DTIU... |
| CGEUR/L2525-6T03 | 6 | 34 | 5, 6 | 3.4 | 25 | 25 | 150 | 35 | 25 | 28.9 | DTIU... |

(1) The value for "f" is true when the insert with the width, indicated in "W" in the table is mounted.

• For applicable inserts, see pages 16-24.

SPARE PARTS



| Designation | Clamping screw | Wrench |
|-----------------------|----------------|--------|
| CGEUR/L****-3T02 | CM5X0.8X16-A | P-4 |
| CGEUR/L1616-4T02 | CM6X1X16-A | P-5 |
| CGEUR/L2020-4T02 | CM6X1X20-A | P-5 |
| CGEUR/L2525-4T02/6T03 | CM6X1X25-A | P-5 |

CTIR/L

Boring bars for Internal grooving & turning

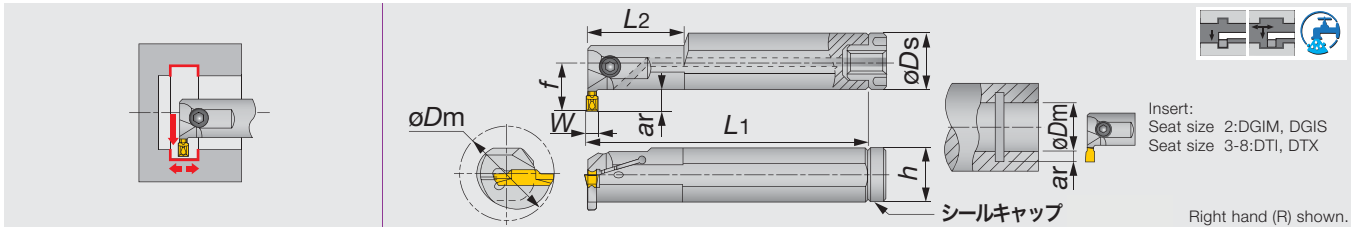

| Designation | W | øD _m | Seat size | ar | øD _s | f | L ₁ ⁽¹⁾ | L ₂ | h | Insert |
|--------------------|---|-----------------|-----------|-----|-----------------|------|-------------------------------|----------------|----|------------------|
| CTIR/L16-2T08-D250 | 2 | 25 | 2 | 8 | 16 | 16.5 | 125 | - | 14 | DGIM..., DGIS... |
| CTIR/L20-2T06-D250 | 2 | 25 | 2 | 6 | 20 | 15.8 | 160 | 40 | 18 | DGIM..., DGIS... |
| CTIR/L20-3T06-D250 | 3 | 25 | 3 | 6 | 20 | 15.8 | 160 | 40 | 18 | DTI..., DTX... |
| CTIR/L25-3T05-D250 | 3 | 25 | 3 | 5.1 | 25 | 17.5 | 200 | 40 | 23 | DTI..., DTX... |
| CTIR/L25-3T08-D320 | 3 | 32 | 3 | 8 | 25 | 21.5 | 200 | 40 | 23 | DTI..., DTX... |
| CTIR/L32-3T10-D400 | 3 | 40 | 3 | 10 | 32 | 27 | 250 | 60 | 30 | DTI..., DTX... |
| CTIR/L20-4T06-D250 | 4 | 25 | 4 | 6 | 20 | 15.8 | 160 | 40 | 18 | DTI..., DTX... |
| CTIR/L25-4T08-D320 | 4 | 32 | 4 | 8 | 25 | 21.5 | 200 | 40 | 23 | DTI..., DTX... |
| CTIR/L32-4T04-D310 | 4 | 31 | 4 | 4 | 32 | 20.8 | 250 | 60 | 30 | DTI..., DTX... |
| CTIR/L32-4T10-D400 | 4 | 40 | 4 | 10 | 32 | 27 | 250 | 60 | 30 | DTI..., DTX... |
| CTIR/L25-5T05-D310 | 5 | 31 | 5 | 5 | 25 | 17.3 | 200 | 60 | 23 | DTI..., DTX... |
| CTIR/L32-5T10-D400 | 5 | 40 | 5 | 10 | 32 | 27 | 250 | 60 | 30 | DTI..., DTX... |
| CTIR/L32-6T04-D310 | 6 | 31 | 6 | 4 | 32 | 20.8 | 250 | 60 | 30 | DTI..., DTX... |
| CTIR/L32-6T10-D400 | 6 | 40 | 6 | 10 | 32 | 27 | 250 | 60 | 30 | DTI..., DTX... |
| CTIR/L32-8T05-D370 | 8 | 37 | 8 | 5 | 32 | 21.3 | 250 | 60 | 30 | DTI..., DTX... |
| CTIR/L40-8T05-D420 | 8 | 42 | 8 | 5.8 | 40 | 25.8 | 300 | 65 | 38 | DTI..., DTX... |

(1) The value for "f" is true when the insert with the width, indicated in "W" in the table is mounted.

• For applicable inserts, see pages 16-24.

SPARE PARTS



| Designation | Clamping screw | Wrench | シールキャップ | 接続用ねじ仕様 |
|--------------------|----------------|--------|---------|---------|
| CTIR/L16-2T08-D250 | CM5X0.8X10-A | P-4 | CA-16 | M6 |
| CTIR/L20-2T06-D250 | CM5X0.8X12-A | P-4 | CA-20 | M6 |
| CTIR/L20-3T06-D250 | CM5X0.8X12-A | P-4 | CA-20 | M6 |
| CTIR/L25-3T05-D250 | CM5X0.8X16-A | P-4 | CA-25 | R1/8" |
| CTIR/L25-3T08-D320 | CM5X0.8X16-A | P-4 | CA-25 | R1/8" |
| CTIR/L32-3T10-D400 | CM5X0.8X16-A | P-4 | CA-32 | R1/8" |
| CTIR/L20-4T06-D250 | CM5X0.8X12-A | P-4 | CA-20 | M6 |
| CTIR/L25-4T08-D320 | CM5X0.8X16-A | P-4 | CA-25 | R1/8" |
| CTIR/L32-4T04-D310 | CM5X0.8X16-A | P-4 | CA-32 | R1/8" |
| CTIR/L32-4T10-D400 | CM5X0.8X16-A | P-4 | CA-32 | R1/8" |
| CTIR/L25-5T05-D310 | CM6X1X16-A | P-5 | CA-25 | R1/8" |
| CTIR/L32-5T10-D400 | CM6X1X20-A | P-5 | CA-32 | R1/8" |
| CTIR/L32-6T04-D310 | CM6X1X20-A | P-5 | CA-32 | R1/8" |
| CTIR/L32-6T10-D400 | CM6X1X20-A | P-5 | CA-32 | R1/8" |
| CTIR/L32-8T05-D370 | CM6X1X25-A | P-5 | CA-32 | R1/8" |
| CTIR/L40-8T05-D420 | CM6X1X25-A | P-5 | CA-40 | R1/8" |

Minimum diameters (øD_m) for inserts other than the above

| Insert | Groove width | |
|-----------------------|--------------|---------------------------|
| | W | Min. dia. øD _m |
| DGM / DGS / SGN | 3 | 50 |
| DGM / DGS / SGN / DTM | 4 | 50 |
| DGM / DGS / DTM | 5 | 60 |
| DGM / DGS / DTM | 6 | 60 |
| DGM / DGS / DTM | 8 | 70 |
| DTE / DGG | 3 | 40 |
| DTE / DGG | 4 | 40 |
| DTE / DGG | 5 | 50 |
| DTE / DGG | 6 | 50 |
| DTE / DGG | 8 | 62 |
| DTR | 3 | 38 |
| DTR | 4 | 38 |
| DTR | 5 | 43 |
| DTR | 6 | 46 |
| DTR | 8 | 56 |

CTIFR/L

Toolholders for face / internal face grooving & turning

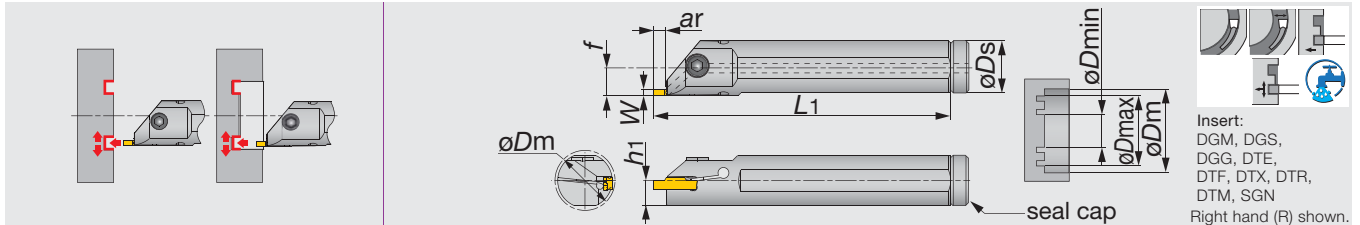

| Designation | W | Seat size | ar | øDs | h1 | L1 | f ⁽¹⁾ |
|---------------------|---|-----------|-----|-----|------|-----|------------------|
| CTIFR/L25-4T05-D270 | 4 | 3, 4 | 5.5 | 25 | 11.5 | 200 | 13.3 |
| CTIFR/L32-4T05-D340 | 4 | 3, 4 | 5.5 | 32 | 15 | 250 | 16.8 |
| CTIFR/L25-5T05-D270 | 6 | 5, 6 | 5.5 | 25 | 11.5 | 200 | 13.3 |
| CTIFR/L32-5T05-D340 | 6 | 5, 6 | 5.5 | 32 | 15 | 250 | 16.8 |

(1) The value for "f" is true when the insert with the width, indicated in "W" in the table is mounted.

• For applicable inserts, see pages 16-24.

SPARE PARTS



| Designation | Clamping screw | Wrench | Seal cap |
|---------------------|----------------|--------|----------|
| CTIFR/L25-4T05-D270 | CM6X1X16-A | P-5 | CA-25 |
| CTIFR/L32-4T05-D340 | CM6X1X20-A | P-5 | CA-32 |
| CTIFR/L25-5T05-D270 | CM6X1X16-A | P-5 | CA-25 |
| CTIFR/L32-5T05-D340 | CM6X1X20-A | P-5 | CA-32 |

| Seat size | øDs | | Minimum diameter øDmin | | | | øDmax |
|-----------|-------|-------|------------------------|---------------|-----------|-----|-------|
| | 25 mm | 32 mm | DGM, DGS, SGN | DTE, DGG, DTM | DTF / DTX | DTR | |
| 3 | 26.3 | 33.3 | 92 | 62 | 19 | 44 | ∞ |
| 4 | 26.8 | 33.8 | 37 | 42 | 20 | 32 | ∞ |
| 5 | 26.3 | 33.3 | 60 | 64 | 20 | 48 | ∞ |
| 6 | 26.8 | 33.8 | 57 | 61 | 23 | 48 | ∞ |

CGIUR/L

Boring bars for internal undercutting

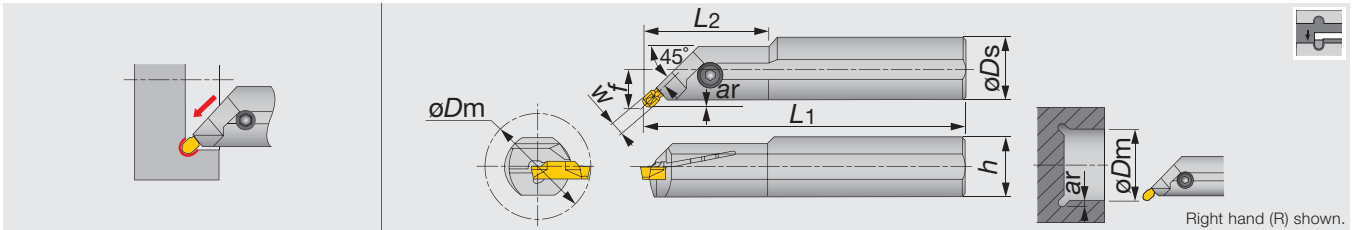

| Designation | W | øD _m | Seat size | ar | øD _s | f ⁽¹⁾ | L ₁ | L ₂ | h | Insert |
|---------------------|---|-----------------|-----------|-----|-----------------|------------------|----------------|----------------|----|---------|
| CGIUR/L20-3T02-D380 | 3 | 38 | 3 | 2.8 | 20 | 12.8 | 160 | - | 19 | DTIU... |
| CGIUR/L25-3T02-D380 | 3 | 38 | 3 | 2.8 | 25 | 14.8 | 200 | 40 | 23 | DTIU... |
| CGIUR/L20-4T02-D380 | 4 | 38 | 4 | 2.8 | 20 | 12.9 | 160 | - | 19 | DTIU... |
| CGIUR/L25-4T02-D460 | 4 | 46 | 4 | 2.8 | 25 | 14.9 | 200 | 40 | 23 | DTIU... |
| CGIUR/L25-6T02-D460 | 6 | 46 | 5, 6 | 2.8 | 25 | 15.2 | 200 | - | 23 | DTIU... |

(1) The value for "f" is true when the insert with the width, indicated in "W" in the table is mounted.

• For applicable inserts, see pages 16-24.

SPARE PARTS



| Designation | Clamping screw | Wrench |
|---------------------|----------------|--------|
| CGIUR/L20-3T02-D380 | CM5X0.8X12-A | P-4 |
| CGIUR/L25-3T02-D380 | CM5X0.8X16-A | P-4 |
| CGIUR/L*-4T02-D... | CM5X0.8X16-A | P-4 |
| CGIUR/L25-6T02-D460 | CM6X1X25-A | P-5 |

CTFR/L

Toolholders for face grooving & turning

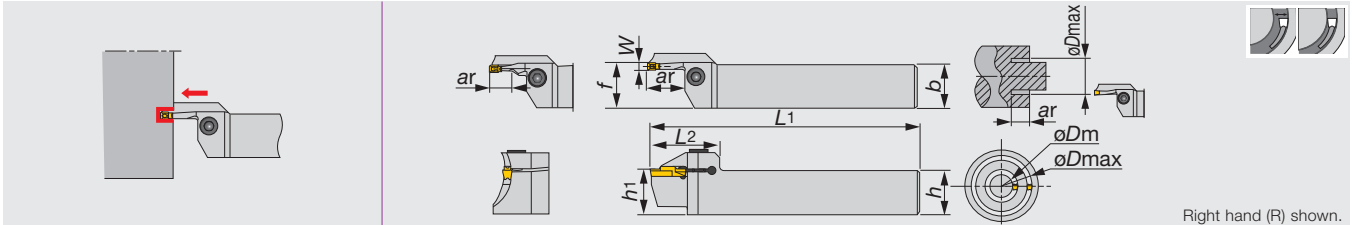

| Designation | W | øD _m | øD _{max} | Seat size | ar | h | b | L ₁ | L ₂ | h ₁ | f ⁽¹⁾ |
|------------------------|---|-----------------|-------------------|-----------|----|----|----|----------------|----------------|----------------|------------------|
| CTFR/L2525-3T10-024035 | 3 | 24 | 35 | 3 | 10 | 25 | 25 | 150 | 38 | 25 | 25.5 |
| CTFR/L2525-3T10-029040 | 3 | 29 | 40 | 3 | 10 | 25 | 25 | 150 | 38 | 25 | 25.5 |
| CTFR/L2525-3T10-034050 | 3 | 34 | 50 | 3 | 10 | 25 | 25 | 150 | 38 | 25 | 25.5 |
| CTFR/L2525-3T15-044070 | 3 | 44 | 70 | 3 | 15 | 25 | 25 | 150 | 38 | 25 | 25.5 |
| CTFR/L2525-3T15-064100 | 3 | 64 | 100 | 3 | 15 | 25 | 25 | 150 | 38 | 25 | 25.5 |
| CTFR/L2525-4T10-022036 | 4 | 22 | 36 | 4 | 10 | 25 | 25 | 150 | 39 | 25 | 25.6 |
| CTFR/L2525-4T20-028042 | 4 | 28 | 42 | 4 | 20 | 25 | 25 | 150 | 39 | 25 | 25.6 |
| CTFR/L2525-4T20-034050 | 4 | 34 | 50 | 4 | 20 | 25 | 25 | 150 | 39 | 25 | 25.6 |
| CTFR/L2525-4T20-042070 | 4 | 42 | 70 | 4 | 20 | 25 | 25 | 150 | 39 | 25 | 25.6 |
| CTFR/L2525-4T20-062120 | 4 | 62 | 120 | 4 | 20 | 25 | 25 | 150 | 39 | 25 | 25.6 |
| CTFR/L2525-4T20-112200 | 4 | 112 | 200 | 4 | 20 | 25 | 25 | 150 | 39 | 25 | 25.6 |
| CTFR/L2525-5T25-050080 | 5 | 50 | 80 | 5 | 25 | 25 | 25 | 150 | 49 | 25 | 25.6 |
| CTFR/L2525-5T25-070110 | 5 | 70 | 110 | 5 | 25 | 25 | 25 | 150 | 49 | 25 | 25.6 |
| CTFR/L2525-5T25-100150 | 5 | 100 | 150 | 5 | 25 | 25 | 25 | 150 | 49 | 25 | 25.6 |
| CTFR/L2525-5T25-140200 | 5 | 140 | 200 | 5 | 25 | 25 | 25 | 150 | 49 | 25 | 25.6 |
| CTFR/L2525-6T25-048070 | 6 | 48 | 70 | 6 | 25 | 25 | 25 | 150 | 49 | 25 | 25.6 |
| CTFR/L2525-6T25-058100 | 6 | 58 | 100 | 6 | 25 | 25 | 25 | 150 | 49 | 25 | 25.6 |
| CTFR/L2525-6T25-088180 | 6 | 88 | 180 | 6 | 25 | 25 | 25 | 150 | 49 | 25 | 25.6 |
| CTFR/L2525-6T25-168400 | 6 | 168 | 400 | 6 | 25 | 25 | 25 | 150 | 49 | 25 | 25.6 |

- When the groove depth is more than 1.5 mm less than the total insert length, use 1-cornered insert.
- (1) "f" value is calculated with groove width "W" shown in the table.
- When DTF insert is installed, Max "ar" should be 15 mm.
- For applicable inserts, see pages 16-24.

SPARE PARTS

| Designation | Clamping screw | Wrench |
|-----------------------|----------------|--------|
| CTFR/L2525-3T - 4T... | CM6X1X25-A | P-5 |
| CTFR/L2525-5T - 6T... | CM8X1.25X25-A | P-6 |

INSERT

| Designation | Seat size | Insert |
|------------------------|-----------|---|
| CTFR/L2525-3T10-024035 | 3 | DTF, DTX |
| CTFR/L2525-3T10-029040 | 3 | DTF, DTX |
| CTFR/L2525-3T10-034050 | 3 | DTF, DTX |
| CTFR/L2525-3T15-044070 | 3 | DTF, DTX, DTR, DTE, DGG |
| CTFR/L2525-3T15-064100 | 3 | DTF, DTX, DTE, DGG, DGM, DGS, DTR, SGN |
| CTFR/L2525-4T10-022036 | 4 | DTF, DTX |
| CTFR/L2525-4T20-028042 | 4 | DTF, DTX, DTR |
| CTFR/L2525-4T20-034050 | 4 | DTF, DTX, DTE, DGG, DGM, DGS, DTR, DTM |
| CTFR/L2525-4T20-042070 | 4 | DTF, DTX, DTE, DGG, DGM, DGS, DTR, SGN, DTM |
| CTFR/L2525-4T20-062120 | 4 | DTF, DTX, DTE, DGG, DGM, DGS, DTR, SGN, DTM |
| CTFR/L2525-4T20-112200 | 4 | DTF, DTX, DTE, DGG, DGM, DGS, DTR, SGN, DTM |
| CTFR/L2525-5T25-... | 5 | DTX, DTE, DGG, DGM, DGS, DTR, DTM |
| CTFR/L2525-6T25-... | 6 | DTX, DTE, DGG, DGM, DGS, DTR, DTM |

| Insert | Groove width | | Min. dia. for face grooving øD _{min} |
|-----------------|--------------|--|---|
| | W | | |
| DGM / DGS / SGN | 3 | | 92 |
| DGM / DGS / SGN | 4 | | 37 |
| DGM / DGS | 5 | | 60 |
| DGM / DGS | 6 | | 57 |
| DTE / DGG | 3 | | 62 |
| DTE / DGG / DTM | 4 | | 42 |
| DTE / DGG / DTM | 5 | | 64 |
| DTE / DGG / DTM | 6 | | 61 |
| DTR | 3 | | 44 |
| DTR | 4 | | 32 |
| DTR | 5 | | 48 |
| DTR | 6 | | 48 |
| DTX | 3 | | 19 |
| DTX | 4 | | 20 |
| DTX | 5 | | 20 |
| DTX | 6 | | 23 |
| DTF | 3 | | 19 |
| DTF | 4 | | 20 |

CTFVR/L

Perpendicular toolholders for face grooving and turning

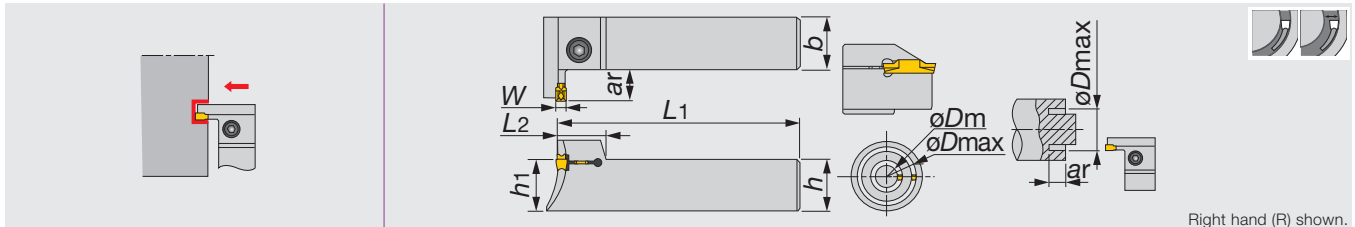

| Designation | W | øD _m | øD _{max} | Seat size | ar | h | b | L ₁ | L ₂ | h ₁ |
|-------------------------|---|-----------------|-------------------|-----------|----|----|----|----------------|----------------|----------------|
| CTFVR/L2525-3T10-024035 | 3 | 24 | 35 | 3 | 10 | 25 | 25 | 150 | 18 | 25 |
| CTFVR/L2525-3T10-029040 | 3 | 29 | 40 | 3 | 10 | 25 | 25 | 150 | 18 | 25 |
| CTFVR/L2525-3T10-034050 | 3 | 34 | 50 | 3 | 10 | 25 | 25 | 150 | 18 | 25 |
| CTFVR/L2525-3T15-044060 | 3 | 44 | 60 | 3 | 15 | 25 | 25 | 150 | 18 | 25 |
| CTFVR/L2525-3T15-054085 | 3 | 54 | 85 | 3 | 15 | 25 | 25 | 150 | 18 | 25 |
| CTFVR/L2525-4T12-022040 | 4 | 22 | 40 | 4 | 12 | 25 | 25 | 150 | 18.5 | 25 |
| CTFVR/L2525-4T15-032050 | 4 | 32 | 50 | 4 | 15 | 25 | 25 | 150 | 18.5 | 25 |
| CTFVR/L2525-4T15-042060 | 4 | 42 | 60 | 4 | 15 | 25 | 25 | 150 | 18.5 | 25 |
| CTFVR/L2525-4T15-052085 | 4 | 52 | 85 | 4 | 15 | 25 | 25 | 150 | 18.5 | 25 |
| CTFVR/L2525-5T20-050080 | 5 | 50 | 80 | 5 | 20 | 25 | 25 | 150 | 22 | 25 |
| CTFVR/L2525-5T20-070110 | 5 | 70 | 110 | 5 | 20 | 25 | 25 | 150 | 22 | 25 |
| CTFVR/L2525-5T20-100150 | 5 | 100 | 150 | 5 | 20 | 25 | 25 | 150 | 22 | 25 |
| CTFVR/L2525-5T20-140200 | 5 | 140 | 200 | 5 | 20 | 25 | 25 | 150 | 22 | 25 |
| CTFVR/L2525-6T20-048085 | 6 | 48 | 85 | 6 | 20 | 25 | 25 | 150 | 22 | 25 |
| CTFVR/L2525-6T20-073150 | 6 | 73 | 150 | 6 | 20 | 25 | 25 | 150 | 22 | 25 |
| CTFVR/L2525-6T20-138250 | 6 | 138 | 250 | 6 | 20 | 25 | 25 | 150 | 22 | 25 |

(1) The value for "h" is true when the insert with the width, indicated in "W" in the table is mounted.

• For applicable inserts, see pages 16-24.

SPARE PARTS

| Designation | Clamping screw | Wrench |
|--------------------------|----------------|--------|
| CTFVR/L2525-3T... | CM5X0.8X25-A | P-4 |
| CTFVR/L2525-4T... | CM6X1X25-A | P-5 |
| CTFVR/L2525-5T..., 6T... | CM8X1.25X25-A | P-6 |

INSERT

| Designation | Seat size | Insert |
|-------------------------|-----------|---|
| CTFVR/L2525-3T10-024035 | 3 | DTF, DTX |
| CTFVR/L2525-3T10-029040 | 3 | DTF, DTX |
| CTFVR/L2525-3T10-034050 | 3 | DTF, DTX, DTR |
| CTFVR/L2525-3T15-044060 | 3 | DTF, DTX, DTE, DTR |
| CTFVR/L2525-3T15-054085 | 3 | DTF, DTX, DTE, DGG, DTR |
| CTFVR/L2525-4T12-022040 | 4 | DTF, DTX, DTR |
| CTFVR/L2525-4T15-032050 | 4 | DTF, DTX, DTE, DGG, DGM, DGS, DTR, DTM |
| CTFVR/L2525-4T15-042060 | 4 | DTF, DTX, DTE, DGG, DGM, DGS, DTR, SGN, DTM |
| CTFVR/L2525-4T15-052085 | 4 | DTF, DTX, DTE, DGG, DGM, DGS, DTR, SGN, DTM |
| CTFVR/L2525-5T20-... | 5 | DTX, DTE, DGG, DGM, DGS, DTR, DTM |
| CTFVR/L2525-6T20-... | 6 | DTX, DTE, DGG, DGM, DGS, DTR, DTM |

| Insert | Groove width | |
|-----------------|--------------|---|
| | W | Min. dia. for face grooving øD _{min} |
| DGM / DGS / SGN | 3 | 92 |
| DGM / DGS / SGN | 4 | 37 |
| DGM / DGS | 5 | 60 |
| DGM / DGS | 6 | 57 |
| DTE / DGG | 3 | 62 |
| DTE / DGG / DTM | 4 | 42 |
| DTE / DGG / DTM | 5 | 64 |
| DTE / DGG / DTM | 6 | 61 |
| DTR | 3 | 44 |
| DTR | 4 | 32 |
| DTR | 5 | 48 |
| DTR | 6 | 48 |
| DTX | 3 | 19 |
| DTX | 4 | 20 |
| DTX | 5 | 20 |
| DTX | 6 | 23 |
| DTF | 3 | 19 |
| DTF | 4 | 20 |

CTER/L-15A

Toolholders for machining aluminum wheel, square shank

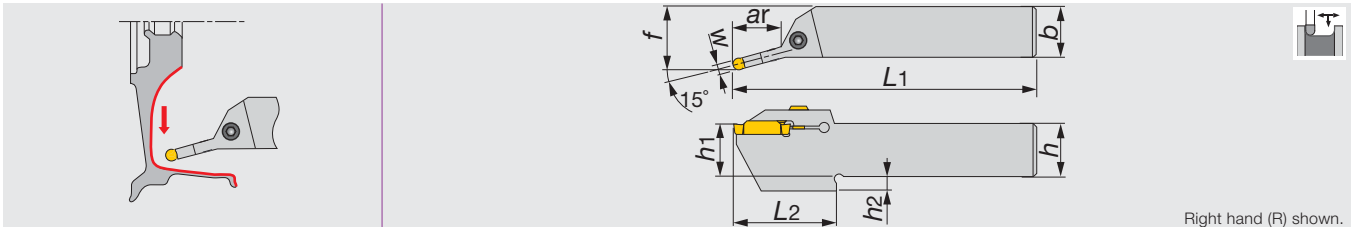

Right hand (R) shown.

| Designation | W | Seat size | ar | h | b | L ₁ | f | L ₂ | h ₁ | h ₂ | Insert |
|---------------------|---|-----------|----|----|----|----------------|------|----------------|----------------|----------------|--------|
| CTER/L2525-6T25-15A | 6 | 6 | 25 | 25 | 25 | 150 | 32.2 | 50.5 | 25 | 7 | DTA... |
| CTER/L2525-8T30-15A | 8 | 8 | 30 | 25 | 25 | 150 | 32.9 | 55 | 25 | 7 | DTA... |

• For applicable inserts, see pages 16-24.

SPARE PARTS

| Designation | Clamping screw | Wrench |
|---------------------|----------------|--------|
| CTER/L2525-****-15A | CM6X1X25-A | P-5 |

CGIUR/L-15A

Boring bars for machining aluminum wheel

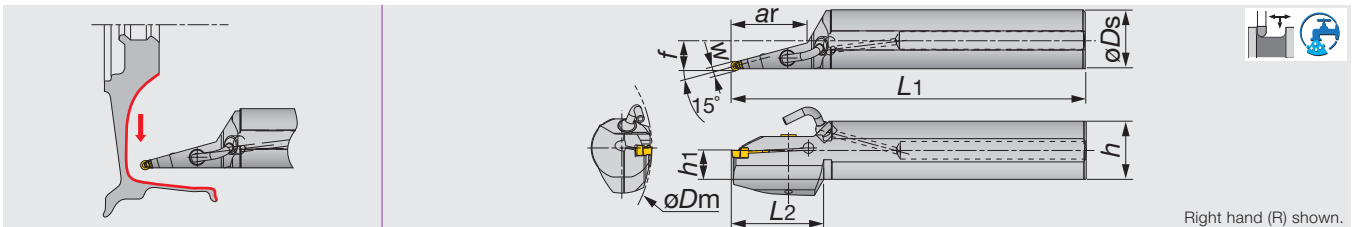

Right hand (R) shown.

| Designation | W | øD _m | Seat size | ar | øD _s | f | L ₁ | L ₂ | h | h ₁ | Insert |
|-------------------------|---|-----------------|-----------|----|-----------------|------|----------------|----------------|------|----------------|--------|
| CGIUR/L40-6T50-D160-15A | 6 | 160 | 6 | 50 | 40 | 19.7 | 320 | 60 | 38.5 | 19 | DTA... |
| CGIUR/L40-8T83-D160-15A | 8 | 160 | 8 | 83 | 40 | 20.5 | 320 | 85 | 38.5 | 19 | DTA... |
| CGIUR/L50-6T85-D200-15A | 6 | 200 | 6 | 85 | 50 | 25.2 | 350 | 85 | 48.5 | 23.5 | DTA... |
| CGIUR/L50-8T85-D200-15A | 8 | 200 | 8 | 85 | 50 | 25.9 | 350 | 85 | 48.5 | 23.5 | DTA... |

• For applicable inserts, see pages 16-24.

SPARE PARTS

| Designation | Clamping screw | Wrench |
|---------------|----------------|--------|
| CGIUR/L**-15A | CM6X1X25-A | P-5 |

Nozzle parts

| Coolant pipe | Coolant nozzle |
|--------------|----------------|
| PNZ5 | CNZ125 |

JCTER/L

External grooving & parting toolholders for swiss lathes

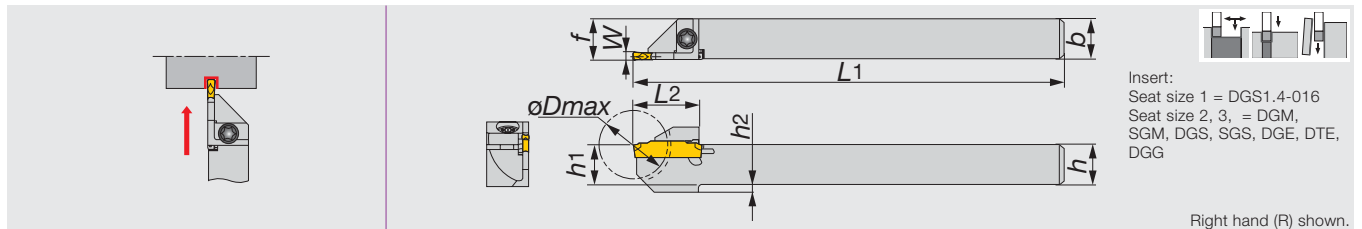

| Designation | W | Seat size | øD _{max} | h | b | L ₁ | L ₂ | h ₁ | f ⁽¹⁾ | h ₂ |
|--------------------|-----|-----------|-------------------|----|----|----------------|----------------|----------------|------------------|----------------|
| JCTER/L1010X1.4T10 | 1.4 | 1 | 20 | 10 | 10 | 120 | 18 | 10 | 10.2 | - |
| JCTER/L1010-1.4T10 | 1.4 | 1 | 20 | 10 | 10 | 125 | 18 | 10 | 10.2 | - |
| JCTER/L1212F1.4T12 | 1.4 | 1 | 24 | 12 | 12 | 85 | 19.5 | 12 | 12.2 | - |
| JCTER/L1212X1.4T12 | 1.4 | 1 | 24 | 12 | 12 | 120 | 19.5 | 12 | 12.2 | - |
| JCTER/L1212-1.4T12 | 1.4 | 1 | 24 | 12 | 12 | 125 | 19.5 | 12 | 12.2 | - |
| JCTER/L1414-1.4T12 | 1.4 | 1 | 24 | 14 | 14 | 125 | 19.5 | 14 | 14.2 | - |
| JCTER/L1616X1.4T16 | 1.4 | 1 | 32 | 16 | 16 | 120 | 24 | 16 | 16.2 | - |
| JCTER/L1616-1.4T16 | 1.4 | 1 | 32 | 16 | 16 | 125 | 24 | 16 | 16.2 | - |
| JCTER/L1010X2T10 | 2 | 2 | 20 | 10 | 10 | 120 | 19 | 10 | 10.1 | 2 |
| JCTER/L1010-2T10 | 2 | 2 | 20 | 10 | 10 | 125 | 19 | 10 | 10.1 | 2 |
| JCTER/L1212F2T12 | 2 | 2 | 24 | 12 | 12 | 85 | 19 | 12 | 12.1 | 2 |
| JCTER/L1212X2T12 | 2 | 2 | 24 | 12 | 12 | 120 | 19 | 12 | 12.1 | 2 |
| JCTER/L1212-2T12 | 2 | 2 | 24 | 12 | 12 | 125 | 19 | 12 | 12.1 | 2 |
| JCTER/L1414-2T12 | 2 | 2 | 24 | 14 | 14 | 125 | 19 | 14 | 14.1 | - |
| JCTER/L1616X2T16 | 2 | 2 | 32 | 16 | 16 | 120 | 24 | 16 | 16.1 | - |
| JCTER/L1616-2T16 | 2 | 2 | 32 | 16 | 16 | 125 | 24 | 16 | 16.1 | - |
| JCTER/L1212F3T12 | 3 | 3 | 24 | 12 | 12 | 85 | 19 | 12 | 12.3 | 2 |
| JCTER/L1212X3T12 | 3 | 3 | 24 | 12 | 12 | 120 | 19 | 12 | 12.3 | 2 |
| JCTER/L1212-3T12 | 3 | 3 | 24 | 12 | 12 | 125 | 19 | 12 | 12.3 | 2 |
| JCTER/L1616X3T16 | 3 | 3 | 32 | 16 | 16 | 120 | 24 | 16 | 16.3 | - |
| JCTER/L1616-3T16 | 3 | 3 | 32 | 16 | 16 | 125 | 24 | 16 | 16.3 | - |
| JCTER/L2020H3T16 | 3 | 3 | 32 | 20 | 20 | 100 | 24 | 20 | 20.3 | - |
| JCTER/L2020-3T16 | 3 | 3 | 32 | 20 | 20 | 125 | 24 | 20 | 20.3 | - |

(1) The value for "f" is true when the insert with the width, indicated in "W" in the table is mounted.

- øD_{max}: Maximum parting-off diameter
- For applicable inserts, see pages 16-24.

SPARE PARTS

| Designation | Clamping screw | Wrench |
|-------------|----------------|--------|
| JCTER/L... | CSHB-4-A | T-15F |



CGER/L

External deep grooving & parting toolholders for swiss lathes

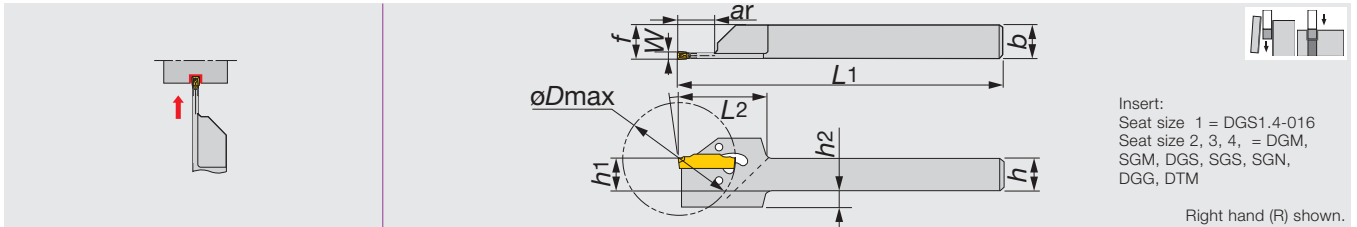

| Designation | W | Seat size | øD _{max} ⁽¹⁾ | ar | h | b | L ₁ | L ₂ | h ₁ | f ⁽²⁾ | h ₂ |
|-------------------|-----|-----------|----------------------------------|------|----|----|----------------|----------------|----------------|------------------|----------------|
| CGER/L2020-1.4T14 | 1.4 | 1 | 29/29 | 9.7 | 20 | 20 | 125 | 31 | 20 | 20.2 | - |
| CGER/L1212-2T17 | 2 | 2 | 35/35 | 11.8 | 12 | 12 | 150 | 31 | 12 | 12.1 | 6 |
| CGER/L1616-2T17 | 2 | 2 | 35/35 | 11.8 | 16 | 16 | 150 | 31 | 16 | 16.1 | 2 |
| CGER/L2020-2T17 | 2 | 2 | 35/35 | 9.8 | 20 | 20 | 125 | 31 | 20 | 20.1 | - |
| CGER/L1212-3T19 | 3 | 3 | 38/40 | 12 | 12 | 12 | 150 | 31 | 12 | 12.3 | 6 |
| CGER/L1616-3T19 | 3 | 3 | 38/45 | 14.9 | 16 | 16 | 150 | 31 | 16 | 16.3 | 2 |
| CGER/L2020-3T19 | 3 | 3 | 38/45 | 13.2 | 20 | 20 | 125 | 31 | 20 | 20.3 | - |
| CGER/L2020-4T19 | 4 | 4 | 38/55 | 20.3 | 20 | 20 | 125 | 33 | 20 | 20.4 | - |

- Wrench, CRW**, should be ordered separately. Insert is clamped by the elastic deformation of upper jaw.
- For applicable inserts, see pages 16-24.
- (1) DG*/SG* Maximum diameter of parting off D_{max}, can be increased by using SG* insert for some toolholders.
- (2) "f" value is calculated with groove width "W" shown in the table.

SPARE PARTS



| Designation | Wrench(Optional) |
|------------------------|------------------|
| CGER/L2020-1.4T14 | CRW23 |
| CGER/L****-2T17 - 4T19 | CRW33 |

CGP

Blades for external deep grooving & parting

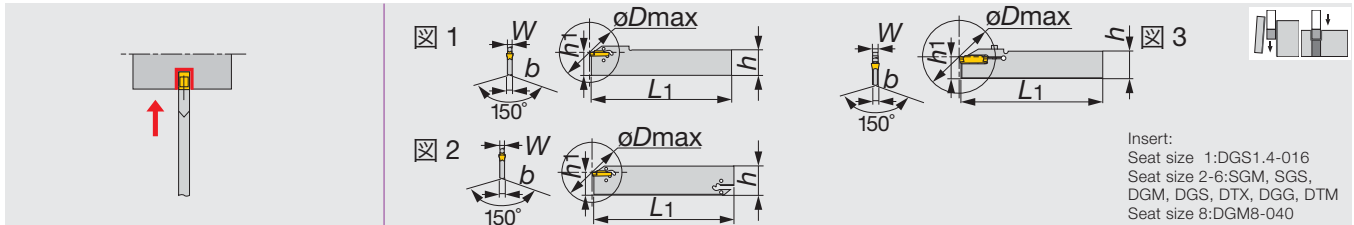

Insert:
 Seat size 1:DGS1.4-016
 Seat size 2-6:SGM, SGS,
 DGM, DGS, DTX, DGG, DTM
 Seat size 8:DGMB-040

| Designation | W | Seat size | øD _{max} | h ₁ | b | h | L ₁ | Fig |
|-------------|-----|-----------|-------------------|----------------|-----|----|----------------|-----|
| CGP26-1.4S | 1.4 | 1 | 26 | 21.4 | 1 | 26 | 150 | 1 |
| CGP32-1.4D | 1.4 | 1 | 26 | 24.8 | 1 | 32 | 150 | 2 |
| CGP26-2S | 2 | 2 | 40 | 21.4 | 1.8 | 26 | 150 | 1 |
| CGP32-2D | 2 | 2 | 50 | 24.8 | 1.8 | 32 | 150 | 2 |
| CGP26-3S | 3 | 3 | 50 | 21.4 | 2.4 | 26 | 150 | 1 |
| CGP32-3D | 3 | 3 | 100 | 24.8 | 2.4 | 32 | 150 | 2 |
| CGP26-4S | 4 | 4 | 80 | 21.4 | 3.2 | 26 | 150 | 1 |
| CGP32-4D | 4 | 4 | 100 | 24.9 | 3.2 | 32 | 150 | 2 |
| CGP45-4D | 4 | 4 | 120 | 38.1 | 3.2 | 45 | 150 | 2 |
| CGP32-5D | 5 | 5 | 120 | 24.9 | 4 | 32 | 150 | 2 |
| CGP32-6D | 6 | 6 | 120 | 24.9 | 5.2 | 32 | 150 | 2 |
| CGP32-8S-CL | 8 | 8 | 80 | 24.9 | 6.2 | 32 | 150 | 3 |

- When the groove depth is more than 1.5 mm less than the total insert length, use 1-cornered insert.
- øD_{max}: Maximum parting-off diameter
- For applicable inserts, see pages 16-24.

SPARE PARTS

| Designation | Clamping screw | Wrench | Wrench(Optional) |
|-----------------|-----------------|--------|------------------|
| CGP**-1.4* | - | - | CRW23 |
| CGP**-2/3/4/5/6 | - | - | CRW33 |
| CGP32-8S-CL | CM4X0.7X20-M0-A | P-3 | - |

- Wrench, CRW**, should be ordered separately.

Caution

Newly developed wrench

Insert is clamped by the elastic deformation of upper jaw.
 Low clamping stress increases the stability and tool life.



CTBF

Tool block for CGP blades(fixed clamp)

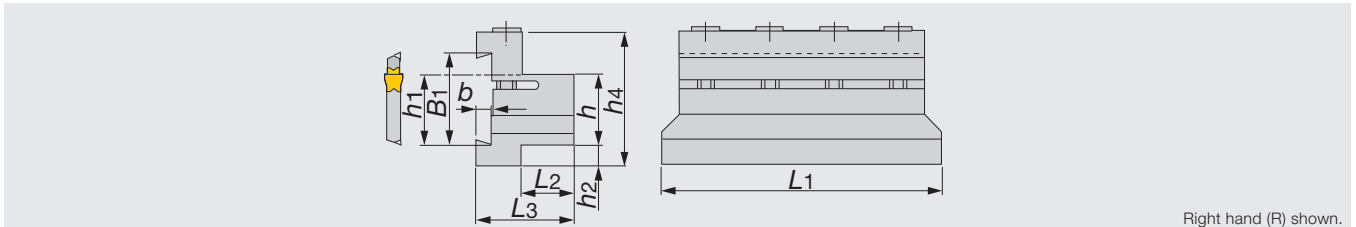

| Designation | h | B_1 | L_2 | L_1 | b | h_1 | h_2 | h_4 | L_3 | Blade (Option) |
|-------------|-----|-------|-------|-------|-----|-------|-------|-------|-------|----------------|
| CTBF25-45 | 25 | 45 | 22 | 110 | 5.5 | 38.1 | 25 | 66 | 40 | CGP45... |
| CTBF32-45 | 32 | 45 | 28 | 120 | 5.5 | 38.1 | 18 | 66 | 45 | CGP45... |

SPARE PARTS



| Designation | Clamping screw | Wrench |
|-------------|----------------|--------|
| CTBF... | CM6X1.0X40-A | P-5 |

CTBU

Tool block for CGP and EGP blades

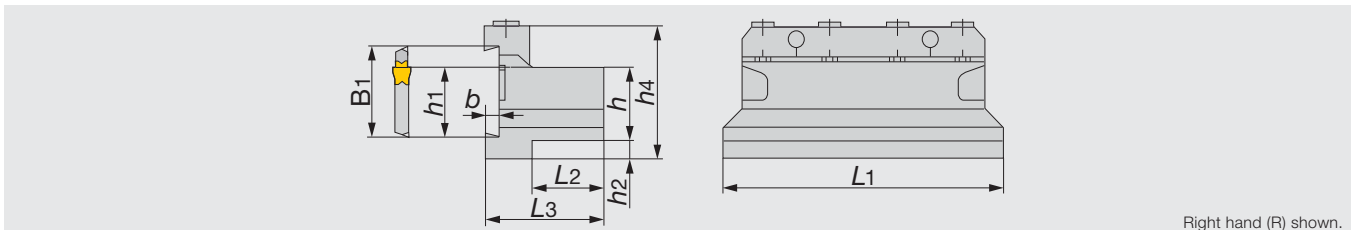

| Designation | h_1 | b | B_1 | L_1 | h | h_2 | h_4 | L_2 | L_3 | Blade (option) |
|-------------|-------|-----|-------|-------|-----|-------|-------|-------|-------|----------------|
| CTBU20-26 | 21.4 | 4 | 26 | 86 | 20 | 9 | 43 | 21 | 38 | CGP26... |
| CTBU25-26 | 21.4 | 4 | 26 | 110 | 25 | 5 | 45 | 23 | 42 | CGP26... |
| CTBU20-32 | 24.8 | 5.3 | 32 | 100 | 20 | 13 | 50 | 19 | 38 | CGP32... |
| CTBU25-32 | 24.8 | 5.3 | 32 | 110 | 25 | 8 | 50 | 23 | 42 | CGP32... |
| CTBU32-32 | 24.8 | 5.3 | 32 | 110 | 32 | 5 | 54 | 29 | 48 | CGP32... |

SPARE PARTS



| Designation | Clamp | Clamping screw | Wrench |
|-------------|--------|----------------|--------|
| CTBU20-26 | CT-86 | CM6X30-S | P-5 |
| CTBU25-26 | CT-105 | CM6X30-S | P-5 |
| CTBU20-32 | CT-100 | CM6X30-S | P-5 |
| CTBU25-32 | CT-110 | CM6X30-S | P-5 |
| CTBU32-32 | CT-110 | CM6X30-S | P-5 |

New

CAER/L-CHP

Modular blade for parting & grooving, with channels for high pressure coolant

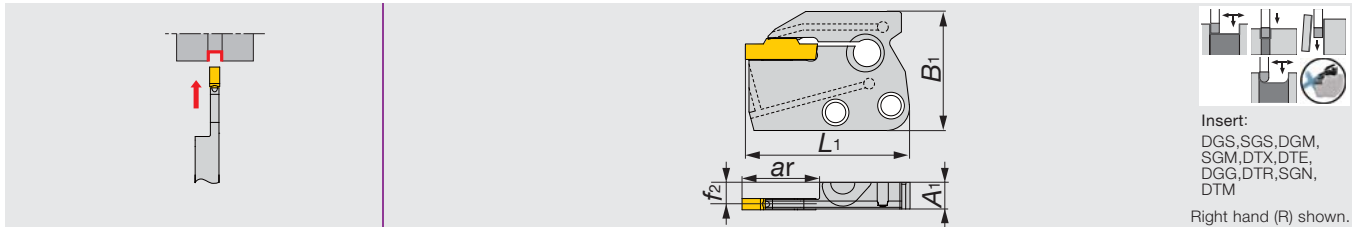

| Designation | W | Seat size | ar | f ₂ | B ₁ | L ₁ | A ₁ |
|-----------------|---|-----------|----|----------------|----------------|----------------|----------------|
| CAER/L-3T20-CHP | 3 | 3 | 20 | 5.95 | 33 | 45.7 | 7.2 |
| CAER/L-4T20-CHP | 4 | 4 | 20 | 5.95 | 33 | 45.7 | 7.2 |

• When the groove depth is more than 1.5 mm less than the total insert length, use 1-cornered insert.

To be released in 2018

New

CHSR/L-CHP

Shank for CAER/L-CHP, with channels for high pressure coolant

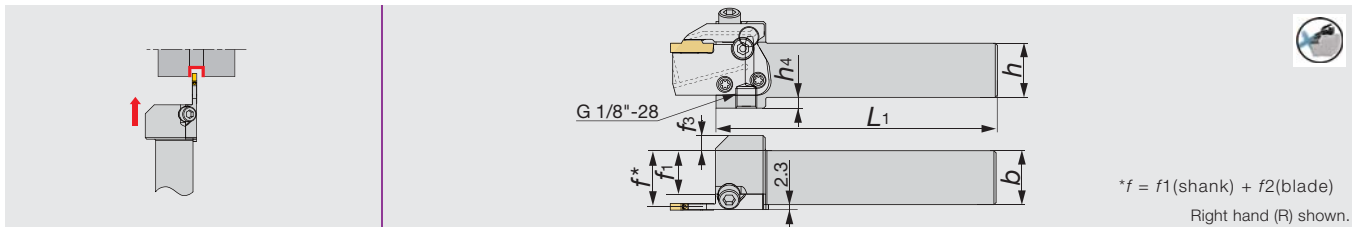

| Designation | h | b | L ₁ | f ₁ | f ₃ | h ₄ |
|----------------|----|----|----------------|----------------|----------------|----------------|
| CHSR/L2020-CHP | 20 | 20 | 130 | 15.1 | 16.5 | 10 |
| CHSR/L2525-CHP | 25 | 25 | 130 | 20.1 | 11.5 | 5 |

• When the groove depth is more than 1.5 mm less than the total insert length, use 1-cornered insert.

To be released in 2018

SPARE PARTS

| Designation | screw | Wrench | Clamping screw | Clamping screw | Wrench | O-ring | Plug |
|---------------|------------|--------|----------------|----------------|--------|--------|-----------------|
| CHSR/L...-CHP | SRM5-04451 | T-20/5 | SRM6X12DIN6912 | SRM6X20-XT | HW5.0 | OR5X1N | PLUGG1/8ISO1179 |

• See page 42 for instruction on installing and removing the blade and insert

• See pages 43 for tube connections

Recommended torque

| Clamping screw | Torque (N · m) |
|----------------|----------------|
| SRM5-04451 | 5 |
| SRM6X12DIN6912 | 8.5 |
| SRM6X20-XT | 8.5 |

New

C*CHSN-CHP

TungCap shank for CAER/L-CHP, with channels for high pressure coolant

TUNGCUT

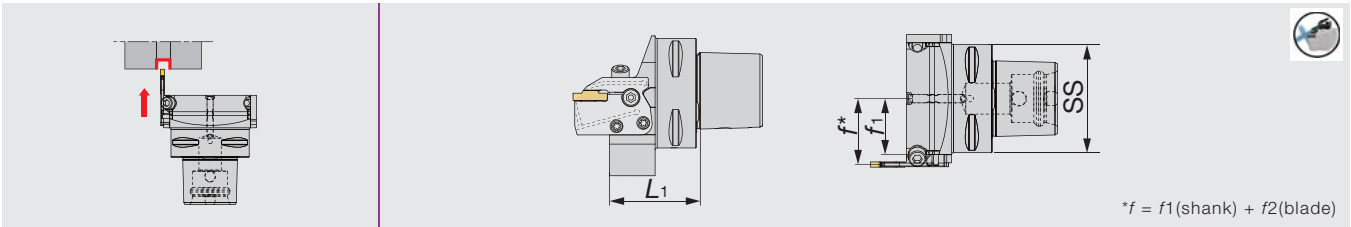

$f^* = f_1(\text{shank}) + f_2(\text{blade})$

| Designation | SS | L ₁ | f ₁ | Blade |
|-----------------|----|----------------|----------------|---------------|
| C4CHSN21047-CHP | 40 | 46.5 | 21 | CAER/L...-CHP |
| C5CHSN26047-CHP | 50 | 47 | 26 | CAER/L...-CHP |
| C6CHSN33050-CHP | 63 | 50 | 32.5 | CAER/L...-CHP |

To be released in 2018

- When the groove depth is more than 1.5 mm less than the total insert length, use 1-cornered insert.

SPARE PARTS

| Designation | Clamping screw | Wrench | Clamping screw | Clamping screw | Wrench | O-ring |
|---------------|----------------|--------|----------------|----------------|--------|--------|
| C*CHSN...-CHP | SRM5-04451 | T-20/5 | SRM6X12DIN6912 | SRM6X20-XT | HW5.0 | OR5X1N |

- See page 42 for instruction on installing and removing the blade and insert

New

C*CHFVN-CHP

TungCap shank for CAER/L-CHP, with channels for high pressure coolant

TUNGCUT

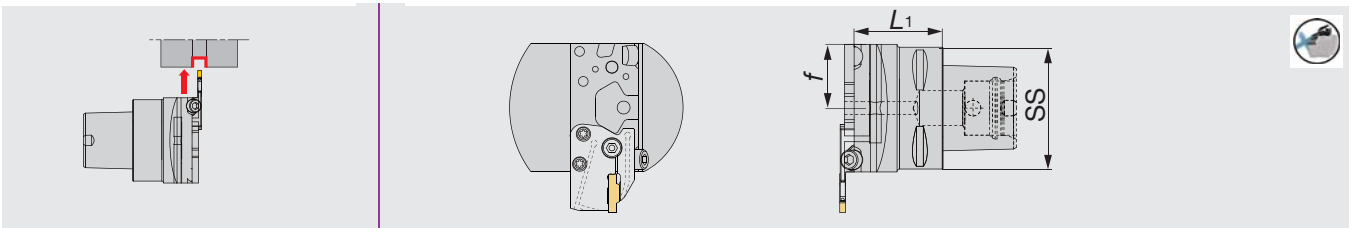

| Designation | SS | L ₁ | f | Blade |
|------------------|----|----------------|----|---------------|
| C4CHFVN26046-CHP | 40 | 46 | 26 | CAER/L...-CHP |
| C5CHFVN26046-CHP | 50 | 46 | 26 | CAER/L...-CHP |
| C6CHFVN33046-CHP | 63 | 46 | 33 | CAER/L...-CHP |

To be released in 2018

- When the groove depth is more than 1.5 mm less than the total insert length, use 1-cornered insert.

SPARE PARTS

| Designation | Clamping screw | Wrench | Clamping screw | Clamping screw | Wrench | O-ring |
|----------------|----------------|--------|----------------|----------------|--------|--------|
| C*CHFVN...-CHP | SRM5-04451 | T-20/5 | SRM6X12DIN6912 | SRM6X20-XT | HW5.0 | OR5X1N |

- See page 42 for instruction on installing and removing the blade and insert

How to install and remove the blade and insert **TUNG-CUT**

Installing the insert

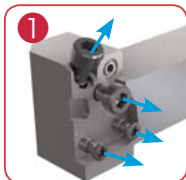

1 Remove all 4 screws and ensure the O rings are all in place.

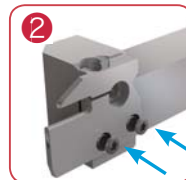

2 Place the blade in the place and tighten 2 bottom clamping screws.

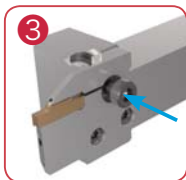

3 Place the insert in the pocket and tighten the fixing screw in the center.

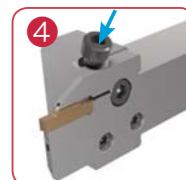

4 Place the long screw in the angular direction and tighten to clamp the insert.

Please follow the installation order as shown above. When the screws are tightened in the 4 → 3 order, the insert clamping may be insufficient and unstable.

Removing the insert

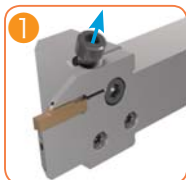

1 First loosen the long screw in the angular direction.

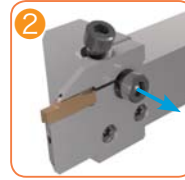

2 Loosen the Fixing screw in the center and remove the insert.

Loosening the long screw alone may not release the insert.

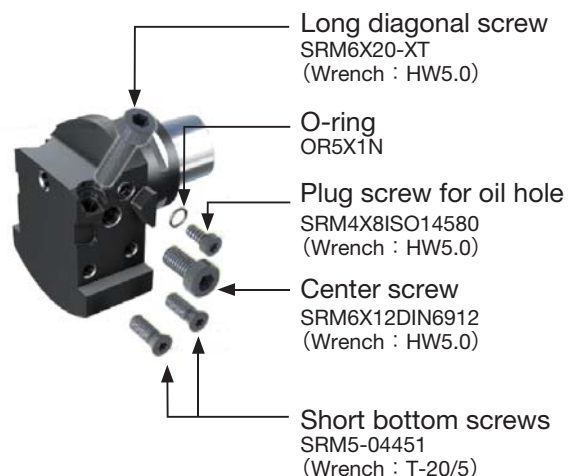
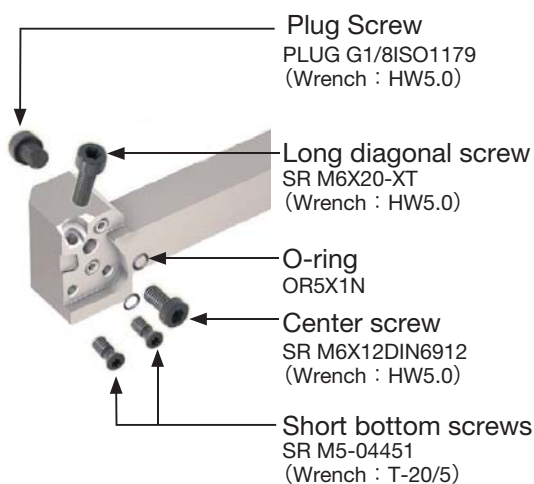

▶ All parts listed here are included in the tool holder.

PARTS FOR COOLANT HOSE

Connecting hose

Fig. 1

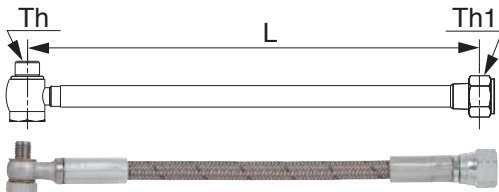
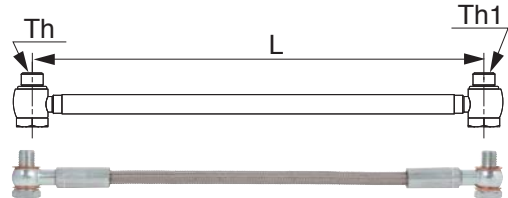
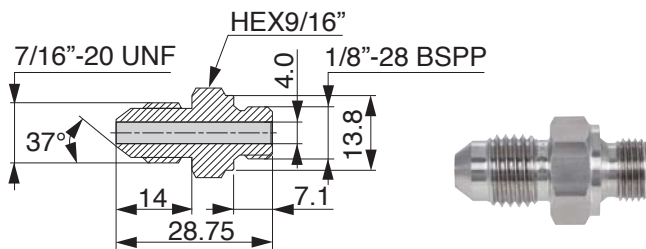

Fig. 2



| Designation | Length L | Threading size | | Max. pressure (Mpa) | Fig. |
|--------------------------|-------------|----------------|---------------|------------------------|------|
| | | Th | Th1 | | |
| CHP-HOSE-G1/8-7/16-200BS | 200 | G1/8"-28 BSPP | 7/16"-20 UNF | 26 | 1 |
| CHP-HOSE-G1/8-7/16-250BS | 250 | G1/8"-28 BSPP | 7/16"-20 UNF | 26 | 1 |
| CHP-HOSE-5/16-7/16-200BS | 200 | 5/16"-24UNF | 7/16"-20 UNF | 20 | 1 |
| CHP-HOSE-5/16-G1/8-200BS | 200 | 5/16"-24UNF | G1/8"-28 BSPP | 20 | 1 |
| CHP-HOSE-G1/8-G1/8-200BB | 200 | G1/8"-28 BSPP | G1/8"-28 BSPP | 26 | 2 |
| CHP-HOSE-G1/8-G1/8-250BB | 250 | G1/8"-28 BSPP | G1/8"-28 BSPP | 26 | 2 |

Adapter



| Designation |
|-------------------------|
| CHP-NIPPLE-G1/8-7/16UNF |

Seal washer

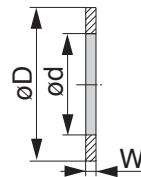

| Designation | øD | ød | W |
|-------------------------|----|----|-----|
| CHP-COPPER-SEAL1/8 | 15 | 8 | 1 |
| CHP-COPPER-SEAL5/16 | 11 | 8 | 1 |
| CHP-COPPER-SEAL5/16-2.5 | 11 | 8 | 2.5 |

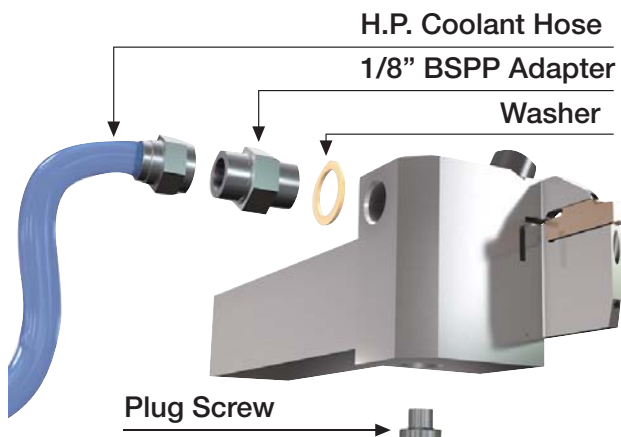

CAER/L

Blades for external grooving & parting & turning

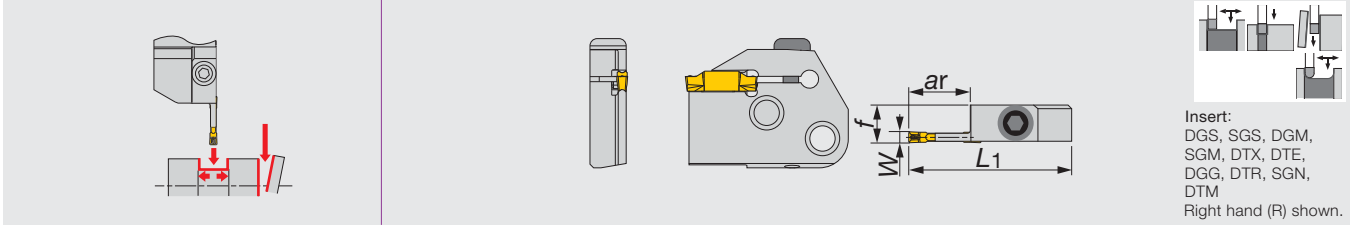

| Designation | W | Seat size | ar | L ₁ | f | Shank |
|-------------|---|-----------|----|----------------|------|-----------------------|
| CAER/L-3T16 | 3 | 3 | 16 | 45 | 10.4 | CHFVL/R..., CHSR/L... |
| CAER/L-4T16 | 4 | 4 | 16 | 45 | 10.5 | CHFVL/R..., CHSR/L... |
| CAER/L-5T20 | 5 | 5 | 20 | 49 | 10.5 | CHFVL/R..., CHSR/L... |
| CAER/L-6T20 | 6 | 6 | 20 | 49 | 10.5 | CHFVL/R..., CHSR/L... |

• For applicable inserts, see pages 16-24.

SPARE PARTS

| Designation | Clamping screw | Wrench |
|-------------|----------------|--------|
| CAER/L... | BHM6-20-A | P-4 |



CAFR/L

Blades for face grooving & turning

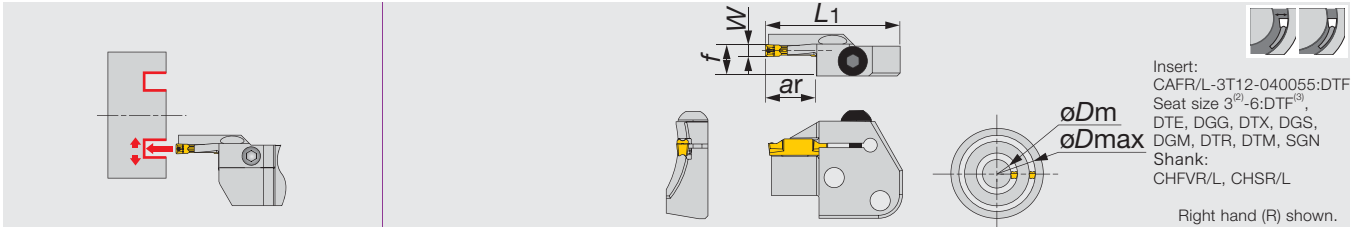

| Designation | W | øD _m | øD _{max} | Seat size | ar | L ₁ | f ⁽¹⁾ |
|--------------------|---|-----------------|-------------------|-----------|----|----------------|------------------|
| CAFR/L-3T12-040055 | 3 | 40 | 55 | 3 | 12 | 45 | 10.4 |
| CAFR/L-3T12-055075 | 3 | 55 | 75 | 3 | 12 | 45 | 10.4 |
| CAFR/L-3T12-075100 | 3 | 75 | 100 | 3 | 12 | 45 | 10.4 |
| CAFR/L-3T12-100140 | 3 | 100 | 140 | 3 | 12 | 45 | 10.4 |
| CAFR/L-3T12-140200 | 3 | 140 | 200 | 3 | 12 | 45 | 10.4 |
| CAFR/L-4T16-050070 | 4 | 50 | 70 | 4 | 16 | 45 | 10.5 |
| CAFR/L-4T16-070100 | 4 | 70 | 100 | 4 | 16 | 45 | 10.5 |
| CAFR/L-4T16-100150 | 4 | 100 | 150 | 4 | 16 | 45 | 10.5 |
| CAFR/L-4T16-150250 | 4 | 150 | 250 | 4 | 16 | 45 | 10.5 |
| CAFR/L-5T20-055080 | 5 | 55 | 80 | 5 | 20 | 49 | 10.5 |
| CAFR/L-5T20-080120 | 5 | 80 | 120 | 5 | 20 | 49 | 10.5 |
| CAFR/L-5T20-120180 | 5 | 120 | 180 | 5 | 20 | 49 | 10.5 |
| CAFR/L-5T20-180300 | 5 | 180 | 300 | 5 | 20 | 49 | 10.5 |
| CAFR/L-5T20-300000 | 5 | 300 | ∞ | 5 | 20 | 49 | 10.5 |
| CAFR/L-6T25-060090 | 6 | 60 | 90 | 6 | 25 | 55 | 10.5 |
| CAFR/L-6T25-090150 | 6 | 90 | 150 | 6 | 25 | 55 | 10.5 |
| CAFR/L-6T25-150250 | 6 | 150 | 250 | 6 | 25 | 55 | 10.5 |
| CAFR/L-6T25-250400 | 6 | 250 | 400 | 6 | 25 | 55 | 10.5 |

• When depth is deeper than (insert length - 1.5 mm), 1 corner type is recommended.

(1) "f" value is calculated with groove width "W" shown in the table.

(2) Not applicable for CAFR/L-3T12-040055

(3) Seat sizes of DTF are Only 3 and 4

• For applicable inserts, see pages 16-24.

SPARE PARTS



| Designation | Clamping screw | Wrench |
|-------------|----------------|--------|
| CAFR/L... | BHM6-20-A | P-4 |

Min. diameter øD_m of DTE, DGS and DGM insert

| Insert | øD _m | Note |
|-------------------------------|-----------------|--|
| DTE 3 / DGS 3 / DGM 3 | ø92 | When diameter is smaller than øD _m , DTF or DTX type insert is recommended. |
| DTE 4 / DGS 4 / DGM 4 / DTM 4 | ø42 | |
| DTE 5 / DGS 5 / DGM 5 / DTM 5 | ø64 | |
| DTE 6 / DGS 6 / DGM 6 / DTM 6 | ø61 | |

CHSR/L

Shank of toolholders for CAER/L & CAFR/L blades

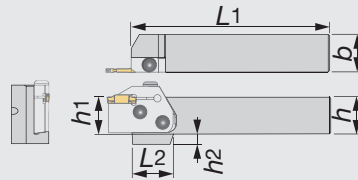

Right hand (R) shown.

| Designation | h | b | L ₁ | L ₂ | h ₁ | h ₂ | Blade |
|-------------|----|----|----------------|----------------|----------------|----------------|----------------------|
| CHSR/L2020 | 20 | 20 | 133 | 35 | 20 | 12 | CAER/L..., CAFL/R... |
| CHSR/L2525 | 25 | 25 | 133 | 28 | 25 | 7 | CAER/L..., CAFL/R... |
| CHSR/L3232 | 32 | 32 | 153 | 28 | 32 | - | CAER/L..., CAFL/R... |

SPARE PARTS



| Designation | Clamping screw | Wrench |
|-------------|----------------|--------|
| CHSR/L... | CSHB-6-A | P-4 |

CHFVR/L

Shank of perpendicular toolholders for CAER/L & CAFR/L blades

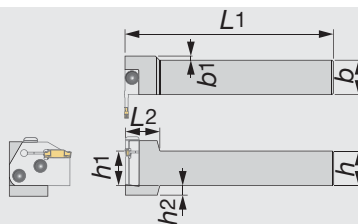

Right hand (R) shown.

| Designation | h | b | L ₁ | L ₂ | h ₁ | h ₂ | b ₁ | Blade |
|-------------|----|----|----------------|----------------|----------------|----------------|----------------|----------------------|
| CHFVR/L2020 | 20 | 20 | 150 | 25 | 20 | 12 | 8 | CAEL/R..., CAFR/L... |
| CHFVR/L2525 | 25 | 25 | 150 | 25 | 25 | 7 | 3 | CAEL/R..., CAFR/L... |
| CHFVR/L3232 | 32 | 32 | 170 | 25 | 32 | - | - | CAEL/R..., CAFR/L... |

SPARE PARTS



| Designation | Clamping screw | Wrench |
|-------------|----------------|--------|
| CHFVR/L... | CSHB-6-A | P-4 |

Combination of blade and toolholder

| Toolholders | Blade | | | |
|-------------|---------|---------|---------|---------|
| | CAER... | CAEL... | CAFR... | CAFL... |
| CHSR... | ● | | | ● |
| CHSL... | | ● | ● | |
| CHFVR... | | ● | ● | |
| CHFVL... | ● | | | ● |

● : Corresponding

C-CHSR/L



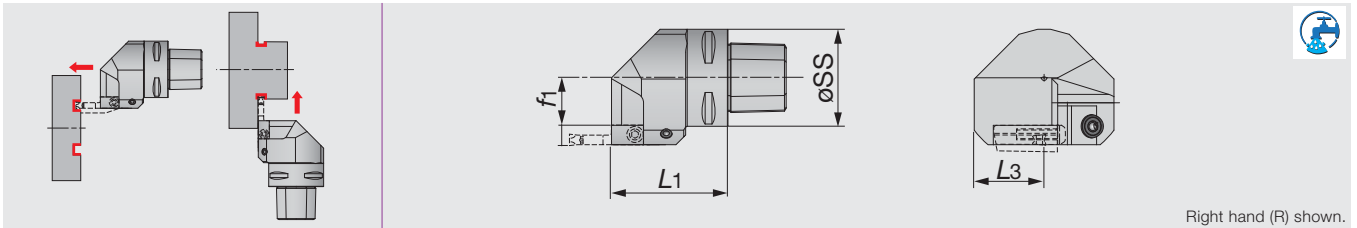

TungCap shank of toolholders for CAER/L & CAFR/L blades



Right hand (R) shown.

| Designation | øSS | L ₁ | L ₃ | f ₁ |
|----------------|-----|----------------|----------------|----------------|
| C3CHSR/L22050N | 32 | 50 | 35 | 11.5 |
| C4CHSR/L27050N | 40 | 50 | 36 | 16.5 |
| C5CHSR/L35060 | 50 | 60 | 36 | 24.5 |
| C5CHSR/L35060N | 50 | 60 | 36 | 24.5 |
| C6CHSR/L45065N | 63 | 65 | 41 | 34.5 |

• The last character of designation is "N": Capable for 7 Mpa coolant pressure.

| SPARE PARTS |  |  |  |  |  |
|----------------|--|--|---|--|--|
| Designation | Coolant parts | Coolant parts 1 | Plug | Clamping screw | Wrench |
| C3CHSR/L22050N | | | | | |
| C4CHSR/L27050N | SATZ-M8X1-M3 | - | SSH4-4 | CSHB-6-A | P-4 |
| C5CHSR/L35060 | CNZ125 | PNZ5 | - | CSHB-6-A | P-4 |
| C5CHSR/L35060N | SATZ-M10X1-M5 | - | SSH4-4 | CSHB-6-A | P-4 |
| C6CHSR/L45065N | SATE-M10X1-M5 | - | SSH4-4 | CSHB-6-A | P-4 |

Combination of blade and toolholder

| Toolholders | Blade | | | |
|-------------|---------|---------|---------|---------|
| | CAER... | CAEL... | CAFR... | CAFL... |
| C*CHSR... | ● | | | ● |
| C*CHSL... | | ● | ● | |
| C*CHFVR... | | ● | ● | |
| C*CHFVL... | ● | | | ● |

● : Corresponding

C-CHFVR/L

TungCap shank of perpendicular toolholders for CAER/L & CAFR/L blades

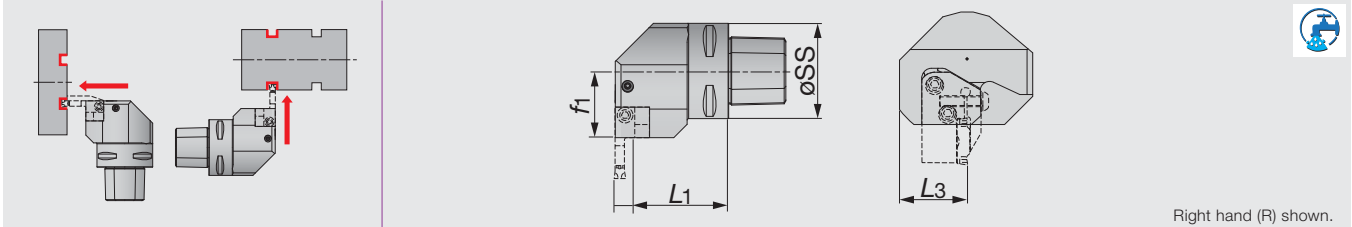

Right hand (R) shown.

| Designation | øSS | L ₁ | L ₃ | f ₁ |
|-----------------|-----|----------------|----------------|----------------|
| C3CHFVR/L22040N | 32 | 32.5 | 35 | 22 |
| C4CHFVR/L27050N | 40 | 42.5 | 36 | 27 |
| C5CHFVR/L35060N | 50 | 49.5 | 36 | 35 |
| C6CHFVR/L45065 | 63 | 54.5 | 41 | 45 |
| C6CHFVR/L45065N | 63 | 54.5 | 41 | 45 |

• The last character of designation is "N": Capable for 7 Mpa coolant pressure.

SPARE PARTS

| Designation | Coolant parts | Coolant parts 1 | Plug | Clamping screw | Wrench |
|-----------------|---------------|-----------------|--------|----------------|--------|
| C3CHFVR/L22040N | SATZ-M8X1-M3 | - | SSH4-4 | CSHB-6-A | P-4 |
| C4CHFVR/L27050N | SATZ-M8X1-M3 | - | SSH4-4 | CSHB-6-A | P-4 |
| C5CHFVR/L35060N | SATZ-M10X1-M5 | - | SSH4-4 | CSHB-6-A | P-4 |
| C6CHFVR/L45065 | CNZ125 | PNZ5 | - | CSHB-6-A | P-4 |
| C6CHFVR/L45065N | SATZ-M10X1-M5 | - | SSH4-4 | CSHB-6-A | P-4 |

STANDARD CUTTING CONDITIONS

| ISO | Workpiece material | Hardness | Priority | Grade | Cutting speed Vc (m/min) |
|----------|---|----------|--------------------------------|---------------|-----------------------------|
| P | Steels C45, 34CrMo4, etc. | < 300 HB | First choice | AH7025, AH725 | 50 - 180 |
| | | < 300 HB | Priority for wear resistance | T9125 | 80 - 200 |
| | | < 300 HB | Priority for impact resistance | GH130 | 50 - 120 |
| | | < 300 HB | Priority for surface finish | NS9530 | 80 - 220 |
| M | Stainless steels X10CrNiS18-9, etc. | < 200 HB | First choice | AH7025, AH725 | 50 - 120 |
| | | < 200 HB | Priority for impact resistance | GH130 | 50 - 120 |
| K | Grey cast irons GG25, 250, etc. | - | First choice | GH130 | 50 - 180 |
| | Ductile cast irons GGG45, 450-10S, etc. | - | First choice | GH130 | 50 - 120 |
| N | Aluminium alloys Si < 12% | - | First choice | TH10 | 100 - 500 |
| | | - | First choice | KS05F | 100 - 600 |
| S | Titanium alloys Ti-6Al-4V, etc. | < HRC 40 | First choice | AH7025 | 20 - 60 |
| | | < HRC 40 | Priority for wear resistance | AH905 | 20 - 80 |
| | | < HRC 40 | First choice | AH905 | 20 - 80 |
| | | < HRC 40 | Priority for impact resistance | AH7025, AH725 | 20 - 80 |
| | | < HRC 40 | Priority for surface finish | KS05F | 20 - 60 |
| H | Hardened steels 34CrMo4, etc. | > HRC 50 | First choice | BX360 | 80 - 150 |

Guideline for ordering special inserts

Specially designed inserts are available upon request.

Acceptable specification

- Specialized inserts must be manufactured from the main insert styles shown below.
- AH725, GH130 and TH10 grades are available.
- ※ Please contact Tungaloy for more details.

| External grooving & turning | | Internal grooving & turning | Profiling & undercutting | |
|---|---|---|---|---|
| DTE (Ground) | DGE (Ground) | DTI (Ground) | DTR (Ground) | DTIU (Ground) |
|  |  |  |  |  |

Designation system for special inserts (sample)

| | | | |
|------------------------|------------------------|--------------------|--------------|
| DTE | 320 | - 000R-025L | AH725 |
| ① Main style of insert | ② Max. width of insert | ③ Additional codes | ④ Grade |

Sample of shape

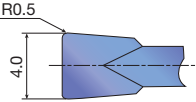
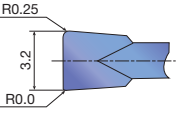
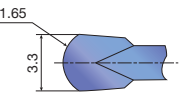
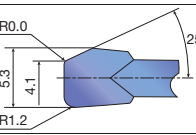
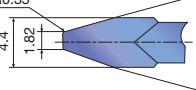
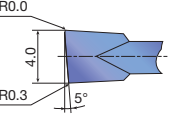
| Shape | Samples of designation | Note |
|---|-------------------------------|---|
|  | DTE400-050 GH130 | Main style: DTE type Special corner radius |
|  | DTE320-000R 025L AH725 | Main style: DTE type Special corner radius, asymmetric type |
|  | DTR330-165 TH10 | Main style: DTR type Full radius type with special insert width |
|  | DTE530-120R-25LA TH10 | Main style: DTE type Special figure of groove, asymmetric type |
|  | DTE440-035-29A TH10 | Main style: DTE type Special figure of groove |
|  | DTE400-030R-005RA TH10 | Main style: DTE type Right handed insert with special angle and corner radius. |

Expedited delivery service for special grooving insert

Expedited delivery service for special grooving inserts is rendered under the following lead time and quantity terms. Please note that this service is applicable only for the order for an initial test batch; a repeat order is to be placed through the regular ordering process.

ORDER
3 - 15 pcs.



LEAD TIME
from the point of order receipt
(excluding transportation)

COATED INSERT
4 weeks

NON-COATED INSERT
3 weeks



DELIVERY



TUNGALLOY
TUNGALLOY

Special width
& corner radii



With chamfer
edges



DGN Chipbreaker



DTE Chipbreaker



| | Grade | |
|--------|----------------|--------|
| | Coated carbide | Cermet |
| | AH725 | NS9530 |
| DGN200 | • | • |
| DGN300 | • | • |
| DGN400 | • | • |
| DGN500 | • | • |
| DGN600 | • | • |
| DTE300 | • | • |
| DTE400 | • | • |
| DTE500 | • | • |
| DTE600 | • | • |
| DTE800 | • | |

Special width & corner radii

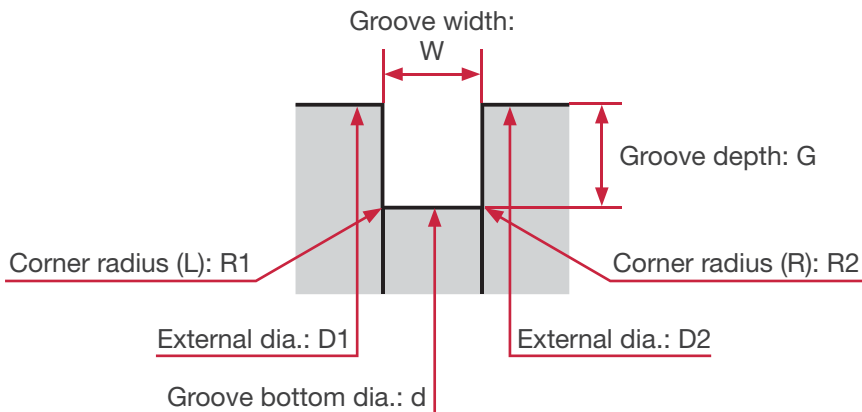

| Edge type | Insert blank | Seat size | Groove width (W) | Max. groove depth (G) | Corner radii (R1 / R2) | Toolholder |
|-----------|--|-------------|------------------|--------------------------|---|------------|
| A | DGN* DTE* | 2 ~ 6 | 0.50 ~ 0.74 mm | ~ 1.5 mm | 0 or 0.05 ~ W/2 (Full radius is available) | CTEFR/L |
| | | | 0.75 ~ 0.99 mm | ~ 1.8 mm | | |
| | | | 1.0 ~ 1.49 mm | ~ 2.5 mm | | |
| | | | 1.50 ~ 6.00 mm | ~ 4.8 mm | | |
| | DGN300/DTE300 | 3 | 2.65 ~ 3.0 mm | Up to holder (Max.18 mm) | | CTER/L |
| | DGN400/DTE400 | 4 | 3.30 ~ 4.0 mm | Up to holder (Max.28 mm) | | CTEFR/L |
| B | DGN500/DTE500 DGN600/DTE600 DTE800 | 5 6 8 | 4.20 ~ 5.0 mm | Up to holder (Max.28 mm) | | CTEFR/L |
| | | | 5.20 ~ 6.0 mm | | | |
| | | | 6.40 ~ 8.0 mm | | | CTER/L |

*Tolerances of the insert are based on the standard item.



Edge type A

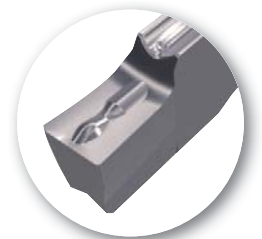

Edge type B

Grooving & chamfering

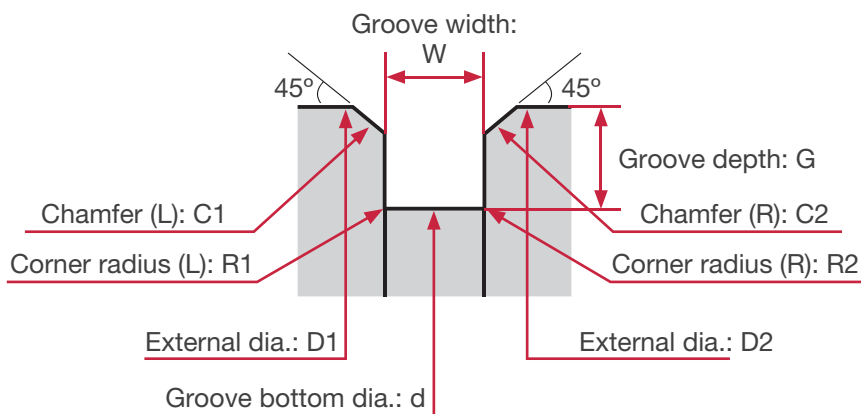

| Insert blank | Seat size | Groove width (W) | Max. groove depth (G) | Corner radii (R1 / R2) | Toolholder |
|--|-----------|------------------|-----------------------|---|----------------------------------|
| DGN200 DGN300 DGN400 DGN500 DGN600 | 2 ~ 6 | 1.0 ~ 4.8 mm | 1.0 ~ 4.0 mm | 0 or 0.05 ~ W/2 (Full radius is available) | CTEFR/L CTEFR/L (Modified) |

*Tolerances of the insert are based on the standard item.

Max. width of chamfer is 0.5 mm.

Some combinations of a groove width, depth, a corner radius(R), and chamfer may be unable to be manufactured.

PRACTICAL EXAMPLES

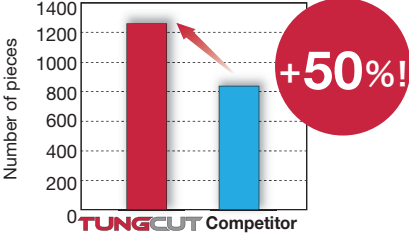
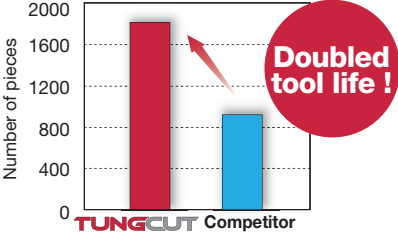
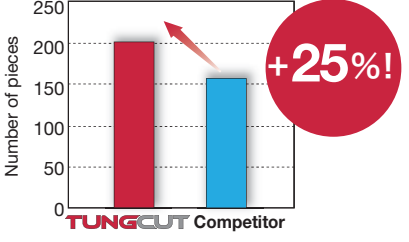
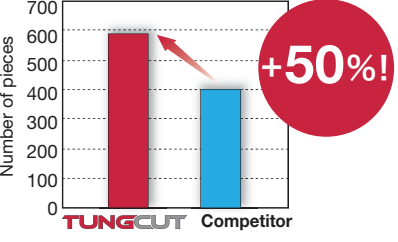
| Workpiece type | | Automotive parts | Machine parts |
|---|--|---|--|
| Toolholder | | CTER1616-2T08 | CTER2525-4T10 |
| Insert | | DGM2-020 | DGM4-030 |
| Grade | | AH725 | AH725 |
| Workpiece material | | SCr440 / 41Cr4 | SCr440 / 41Cr4 |
| Cutting conditions | | | |
| Grooving width: <i>W</i> (mm) | | 2 | 4 |
| Cutting speed: <i>V_c</i> (m/min) | | 94 | 150 |
| Feed: <i>f</i> (mm/rev) | | 0.08 | 0.10 |
| Machining | | Parting off | Grooving |
| Cutting edge depth (mm) | | - | 6 |
| Coolant | | Water soluble | Water soluble |
| Results | |  <p>+50%!</p> <p>TungCut has higher wear resistance and achieves tool life improvements of 150%.</p> |  <p>Doubled tool life!</p> <p>TungCut provides better chip control and doubles tool life.</p> |
| Workpiece type | | Machine parts | Gear |
| Toolholder | | CTEL2020-3T09 | CTER2525-2T08 |
| Insert | | DTE3-040 | SGN200-020 |
| Grade | | T9125 | BX360 |
| Workpiece material | | S53C / C53 | SCM415H (58HRC) / 18CrMo4 |
| Cutting conditions | | | |
| Grooving width: <i>W</i> (mm) | | 3 | 2 |
| Cutting speed: <i>V_c</i> (m/min) | | 200 | 120 |
| Feed: <i>f</i> (mm/rev) | | 0.2 | 0.05 |
| Machining | | Grooving | Grooving |
| Cutting edge depth (mm) | | 5 | 0.8 |
| Coolant | | Water soluble | Water soluble |
| Results | |  <p>+25%!</p> <p>The excellent wear resistance of TungCut improves tool life by 25%, even when machining at high speed.</p> |  <p>+50%!</p> <p>TungCut extends tool life by 1.5 times when hardened steel cutting. This is a result of the extremely stable CBN grade.</p> |

MEMO

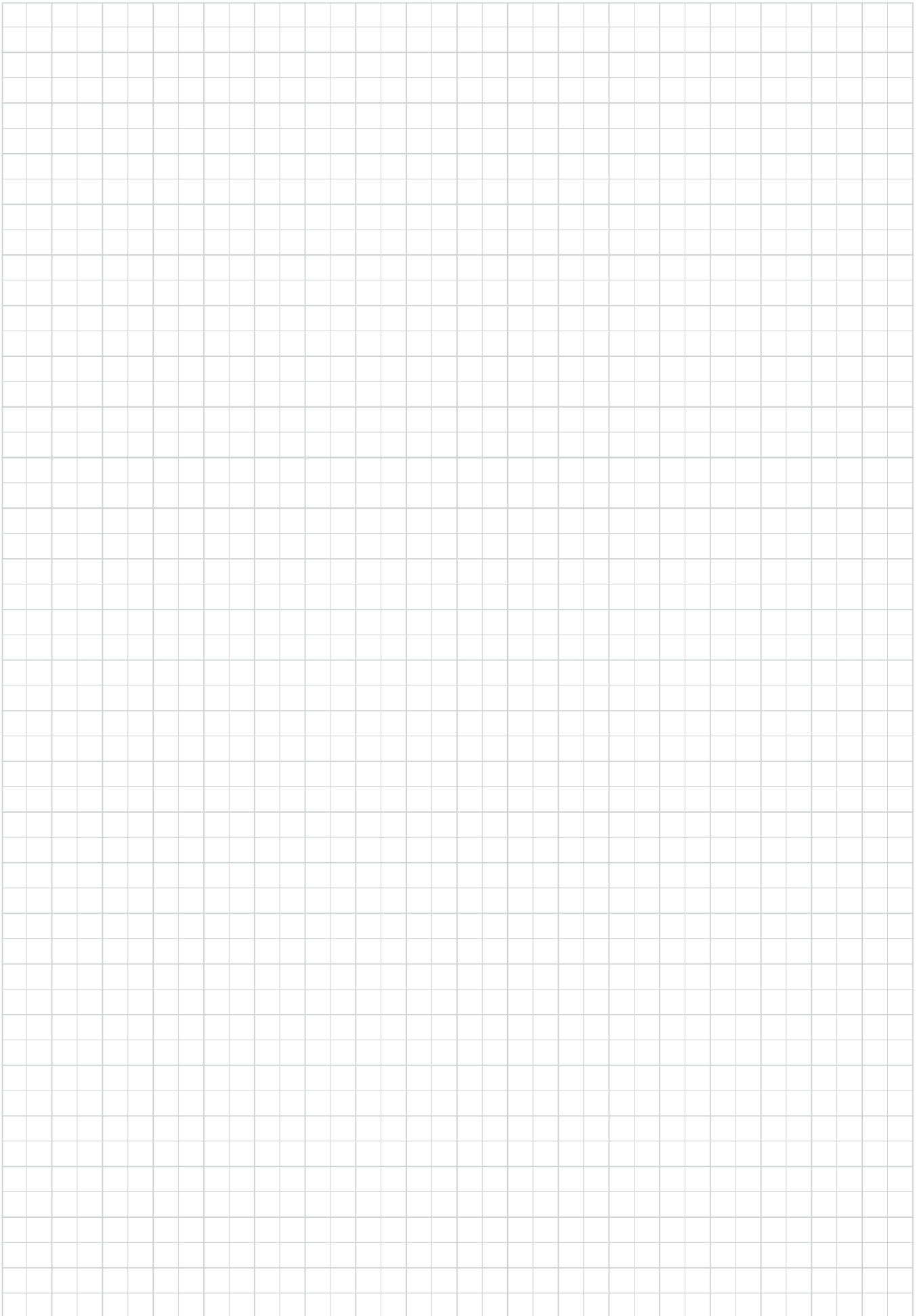
A large grid of graph paper for taking notes, consisting of 20 columns and 30 rows of small squares.



Tungaloy Corporation (Head office)

11-1 Yoshima-Kogyodanchi
Iwaki-city, Fukushima, 970-1144 Japan
Phone: +81-246-36-8501
Fax: +81-246-36-8542
www.tungaloy.co.jp

Tungaloy America, Inc.

3726 N Ventura Drive
Arlington Heights, IL 60004, U.S.A.
Phone: +1-888-554-8394
Fax: +1-888-554-8392
www.tungaloyamerica.com

Tungaloy Canada

432 Elgin St. Unit 3
Brantford, Ontario N3S 7P7, Canada
Phone: +1-519-758-5779
Fax: +1-519-758-5791
www.tungaloy.com/ca

Tungaloy de Mexico S.A.

C Los Arellano 113,
Parque Industrial Siglo XXI
Aguascalientes, AGS, Mexico 20290
Phone: +52-449-929-5410
Fax: +52-449-929-5411
www.tungaloy.com/mx

Tungaloy do Brasil Ltda.

Avd. Independencia N4158 Residencial Flora
13280-000 Vinhedo, São Paulo, Brasil
Phone: +55-19-38262757
Fax: +55-19-38262757
www.tungaloy.com/br

Tungaloy Germany GmbH

An der Alten Ziegelei 1
D-40789 Monheim, Germany
Phone: +49-2173-90420-0
Fax: +49-2173-90420-19
www.tungaloy.de

Tungaloy France S.A.S.

ZA Courtaboef - Le Rio
1 rue de la Terre de feu
F-91952 Courtaboef Cedex, France
Phone: +33-1-6486-4300
Fax: +33-1-6907-7817
www.tungaloy.fr

Tungaloy Italia S.r.l.

Via E. Andolfato 10
I-20126 Milano, Italy
Phone: +39-02-252012-1
Fax: +39-02-252012-65
www.tungaloy.it

Tungaloy Czech s.r.o.

Turanka 115
CZ-627 00 Brno, Czech Republic
Phone: +420-532 123 391
Fax: +420-532 123 392
www.tungaloy.cz

Tungaloy Ibérica S.L.

C/Miquel Servet, 43B, Nau 7
Pol. Ind. Bufalvent
ES-08243 Manresa (BCN), Spain
Phone: +34 93 113 1360
Fax: +34 93 876 2798
www.tungaloy.es

Tungaloy Scandinavia AB

Bultgatan 38
442 40 Kungälv, Sweden
Phone: +46-462119200
www.tungaloy.se

Tungaloy Rus, LLC

115432, Russian Federation, Moscow,
Andropova avenue., h.18, bld.7, flt. 11,
office 3.
Phone: +7-499-683-01-80/81
www.tungaloy.com/ru

Tungaloy East LLC

620075, Russian Federation, Sverdlovsk
Region, Ekaterinburg, Mamina-Sibiryaka str.,
bldg. 101, room 202
Phone: +7-343-286-48-23/24
Fax: +7-912-284-91-69
www.tungaloy.com/rue

Tungaloy Polska Sp. z o.o.

ul. Genewska 24
03-963 Warszawa, Poland
Phone: +48-22-617-0890
Fax: +48-22-617-0890
www.tungaloy.com/pl

Tungaloy U.K. Ltd

The Technology Centre,
Wolverhampton Science Park
Glaisher Drive, Wolverhampton
West Midlands WV10 9RU, UK
Phone: +44 121 4000 231
Fax: +44 121 270 9694
www.tungaloy.com/uk
salesinfo@tungaloyuk.co.uk

Tungaloy Hungary Kft

Erzsébet királyné útja 125
H-1142 Budapest, Hungary
Phone: +36 1 781-6846
Fax: +36 1 781-6866
www.tungaloy.com/hu
info@tungaloytools.hu

Tungaloy Turkey

Dudullu, OSB 4. Cad No:4
34776 Umraniye Istanbul, TURKEY
Phone: +90 216 540 04 67
Fax: +90 216 540 04 87
www.tungaloy.com.tr
info@tungaloy.com.tr

Tungaloy Benelux b.v.

Tjalk 70
NL-2411 NZ Bodegraven, Netherlands
Phone: +31 172 630 420
Fax: +31 172 630 429
www.tungaloy-benelux.com

Tungaloy Croatia

Josipa Kozarca 4
10432 Bregana, Croatia
Phone: +385 1 3326 604
Fax: +385 1 3327 683
www.tungaloy.hr

Tungaloy Cutting Tool (Shanghai) Co.,Ltd.

Rm No 401 No.88 Zhabei
Jiangchang No.3 Rd
Shanghai 200436, China
Phone: +86-21-3632-1880
Fax: +86-21-3621-1918
www.tungaloy.com/tcts

Tungaloy Cutting Tool (Thailand) Co.,Ltd.

Interlink tower 4th Fl.
1858/5-7 Bangna-Trad Road
km.5 Bangna, Bangna, Bangkok 10260
Thailand
Phone: +66-2-751-5711
Fax: +66-2-751-5715
www.tungaloy.co/th

Tungaloy Singapore (Pte.), Ltd.

62 Ubi Road 1, #06-11 Oxley BizHub 2
Singapore 408734
Phone: +65-6391-1833
Fax: +65-6299-4557
www.tungaloy.com/tspl

Tungaloy Vietnam

LE 04-38, Lexington Residence
67 Mai Chi Tho, Dist. 2,
Ho Chi Minh City, Vietnam
Phone: +84-8-37406660
Fax: +84-8-37406662
www.tungaloy.com/vsp

Tungaloy India Pvt. Ltd.

Indiabulls Finance Centre,
Unit # 902-A, 9th Floor,
Tower 1, Senapati Bapat Marg,
Elphinstone Road (West),
Mumbai -400013, India
Phone: +91-22-6124-8804
Fax: +91-22-6124-8899
www.tungaloy.com/in

Tungaloy Korea Co., Ltd

#1312, Byucksan Digital Valley 5-cha
Beotkot-ro 244, Geumcheon-gu
153-788 Seoul, Korea
Phone: +82-2-2621-6161
Fax: +82-2-6393-8952
www.tungaloy.com/kr

Tungaloy Malaysia Sdn Bhd

50 K-2, Kelana Mall, Jalan SS6/14
Kelana Jaya, 47301
Petaling Jaya, Selangor Darul Ehsan
Malaysia
Phone: +603-7805-3222
Fax: +603-7804-8563
www.tungaloy.com/my

Tungaloy Australia Pty Ltd

PO Box 2232, Rowville,
Victoria 3178, Australia
Phone: +61-3-9755-8147
Fax: +61-3-9755-6070
www.tungaloy.com.au

PT. Tungaloy Indonesia

Kompleks Grand Wisata Block AA-10 No.3-5
Cibitung
Bekasi 17510, Indonesia
Phone: +62-21-8261-5808
Fax: +62-21-8261-5809
www.tungaloy.com/id



www.tungaloy.com

follow us at:

facebook.com/tungaloyjapan

twitter.com/tungaloyjapan

To see this product in action visit:

Tung-TV

www.youtube.com/tungaloycorporation

Distributed by:



DOWNLOAD
Dr. Carbide App



FIND US ON THE CLOUD!
machiningcloud.com



Available on the
App Store



GET IT ON
Google play



AS9100 Certified
78006
2015.11.04
ISO14001 Certified
EC97J1123
1997.11.26